

1982 MAICO ALPHA



maico alpha 1/alpha e technical information



CONGRATULATIONS!

You are now the owner of the finest production racing motorcycle manufactured. The Maico represents the results of years of thoughtful engineering and development on the race tracks of the world.

Because the Maico is a hybrid machine, it must be treated with the same attitude one would use with a Grand Prix "one-off" special. Maximum performance can only be obtained when the machine is set up and dialed in properly.

This is not to say that a Maico is temperamental and fussy.

Far from it.

The Maico is constructed from the finest materials that the technology of today offers. And, as such, the Maico has durability and long life built in to the vital mechanical components.

However, like any pure racing machine, variables such as carburetion jetting, suspension tuning, gearing and mechanical adjustments can and will make a difference in the basic performance.

This owner's manual, then, is intended to enlighten, inform and prepare the Maico owner for the fierce world of racing competition. In these pages, you'll find information garnered from engineers, tuners, racers and factory mechanics.

Take the time to read and learn this valuable information, and you will be rewarded with a strong-running, reliable bike that is capable of winning at any race track in the world.

Consider: All you have to do to a passenger car is add gasoline and go. A Formula One race car is stressed to the limit and asked to do things the passenger car could never do. A racing motorcycle has more horsepower per cubic inch than a Formula car and is subjected to stresses that are almost unimagineable.

To ensure success, one must be armed with knowledge and apply that knowledge to the machine.

So, study this owner's manual carefully, prepare your machine in a professional manner and reap the rewards that come with being the pilot of a razor-sharp Maico racing motorcycle.

NOTICE: — *Due to constant improvements made to these models over the normal course of a production year, some of the specifications and data in this manual may become outdated. If there are any questions you may have regarding this manual, or your machine, that are not satisfactorily covered, please consult your local Maico dealer.*



Service Department
International Division
Maico Motorcycles
Fahrzeugfabrik GMBH
7403 Ammerbuch 2
West Germany
Telephone: (0 70 73) 824/825
Telex: 7262746

IMPORTANT!

Maico is not responsible for personal injury or damage to the components of the machine. Maico is not responsible for any damage resulting from using methods, or tools, or performing work other than that recommended and/or authorized by Maico USA.

This motocross machine is especially constructed for competition and off-road use only. This machine is sold AS IS with original equipment. This machine does not conform to Federal Safety Standards and operation on public streets, roads, or highways is illegal.

Maico reserves the right to make changes at any time, without notice, and without incurring any obligation whatsoever.

No part of this publication may be reproduced or copies without written permission from Maico USA.

Maico motorcycles are sold on an AS IS basis and, therefore, there are no warranties, expressed or implied. The Purchaser of this motorcycle, which is intended for competition purposes, is responsible for all cost of service and/or repair.

TABLE OF CONTENTS

INTRODUCTION	3
DISCLAIMER	3
TABLE OF CONTENTS	4
BASIC MAINTENANCE, CHECKS AND ADJUSTMENTS	6
PRE-RIDE CHECK LIST	8
Starting, stopping, first ride, break-in, machine familiarization	
AIR FILTER, SERVICE AND PROCEDURE	10
CARBURETOR AND JETTING	12
Low-speed, mid-range, high rpm, the Bing carb, jetting changes, jetting basics, overlapping circuits, detonation and plug readings, ratios/oils/ jetting changes, float level adjustments.	
FORK TUNING	14
Oil levels, pressures, tuning guidelines, oil types and viscosities, adjustments	
FORK DISASSEMBLY	16
Inspection, seal removal and replacement, fork reassembly.	
STEERING HEAD DISASSEMBLY	19
Inspection, bearing and race removal and re- placement, steering head reassembly.	
FRONT WHEEL DISASSEMBLY	21
Wheel and brake inspection/service, wheel bearing service, removal, reinstallation, wheel and brake inspection/service, front brake adjustment.	
REAR WHEEL DISASSEMBLY	25
Inspection/service, bearing removal and reinstallation, chain adjustment, reassembly.	
SHOCK REMOVAL	28
Attaching points/links, service and inspection.	
SHOCK REBUILD	29
Teardown, service, inspection, oils, pressures, reassembly.	

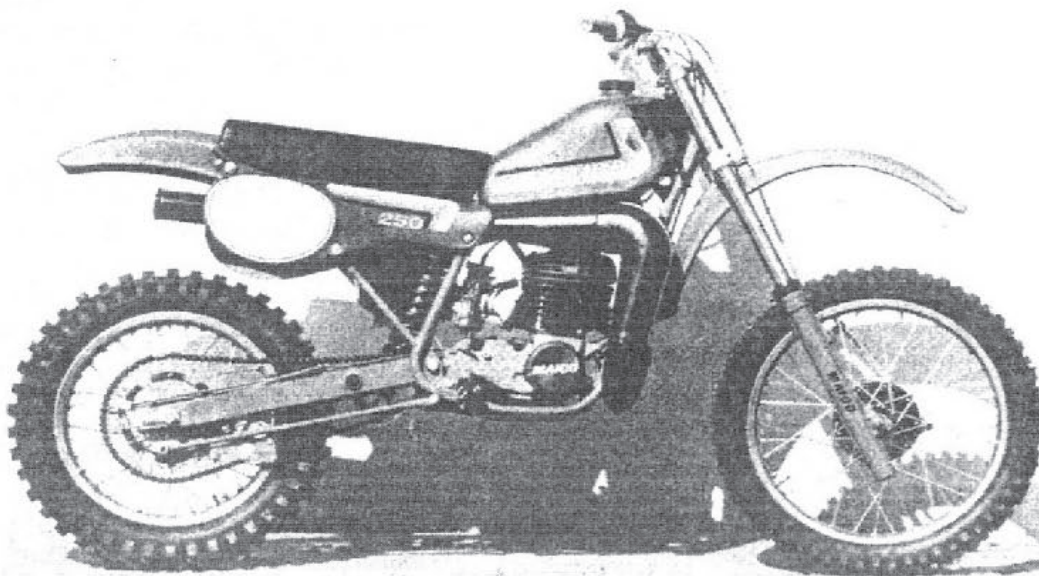

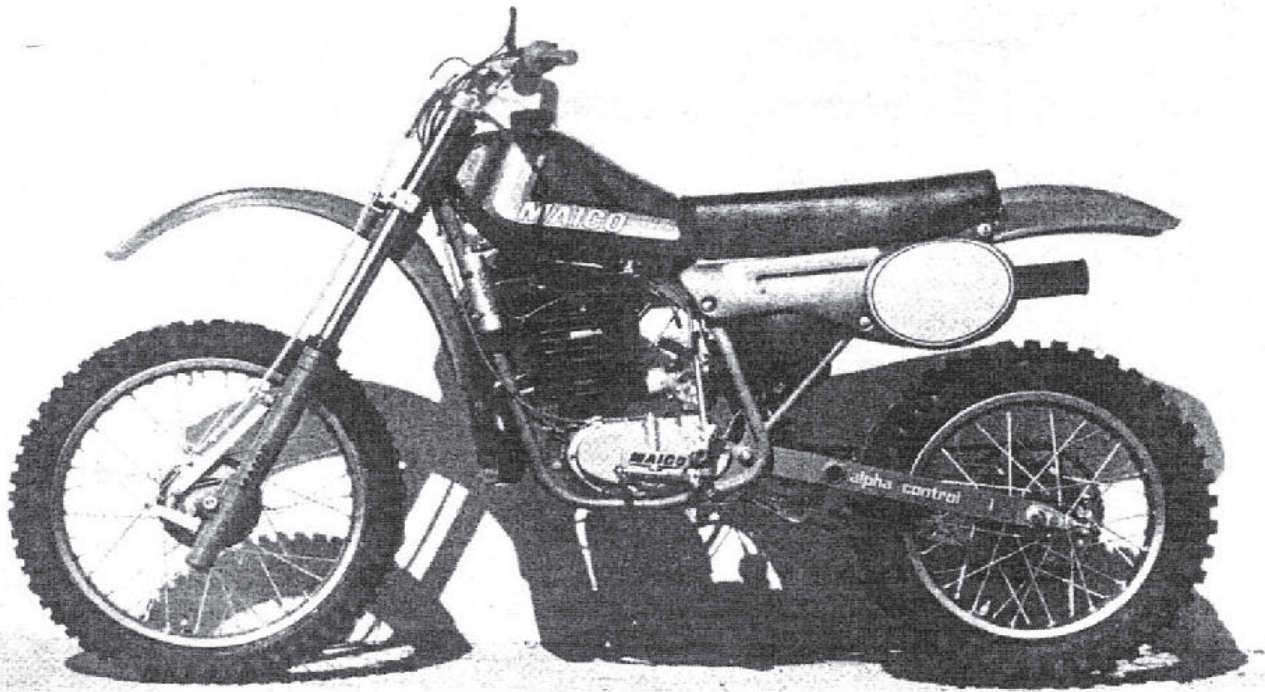

SPECIAL TOOLS	33
Identification, layout.	
ENGINE REMOVAL	33
Step-by-step teardown, parts removal in order, engine mounts, lifting engine from frame.	
ENGINE TEARDOWN, TOP END AND MAG	37
Remove barrel, head, piston and magneto.	
REED ASSEMBLY	40
250 engine only.	
TOP END TOLERANCES	40
Check bore, ring, service limits.	
ENGINE TEARDOWN, PRIMARY SIDE	41
Remove case cover, clutch, chain, primary drive, shifting mechanism.	
ENGINE TEARDOWN, SPLITTING CASES, TRANSMISSION	46
Remove case half, removal and teardown of transmission, shifting plates, 250 case stuffer variation, inspection/service.	
TRANSMISSION LAYOUT CHART	51
250 gearbox, 490 gearbox illustrations.	
CRANK/ROD SET-UP	52
Tolerances, wear limits, illustrations, 250 and 490 lower end.	
ENGINE REASSEMBLY	52
Proper procedure, general information, special notes, check gearbox function, ignition timing, check deck height.	
TROUBLESHOOTING CHART	55
Electrical system, fuel and carburetion, air leaks/connections, mechanical, clutch, shifting, vibration.	
SPECIFICATIONS	56
250 and 490 models, motocross and enduro.	
BLOW-UP CHARTS	57, 58, 59, 60
Engine, chassis, wheels/forks.	
RACING LOG, NOTES	61, 62
Record of hours, jetting, gearing, etc.	

Basic Maintenance, Checks and Adjustments

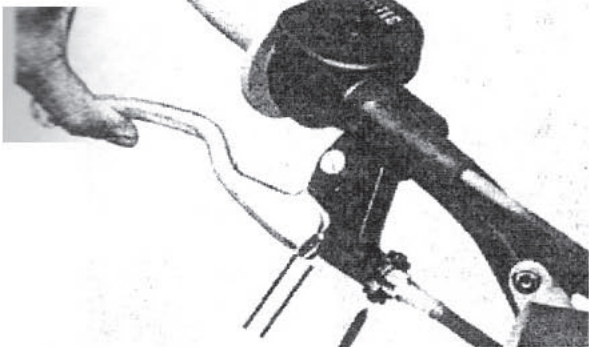

1. The front brake can be adjusted by turning the adjuster indicated by the arrow. You must have at least 5mm of free play where the two lines are indicated.

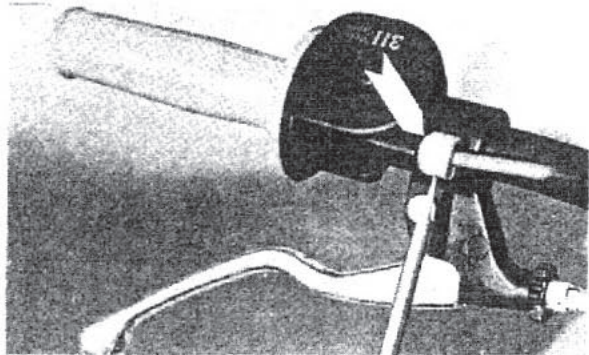

2. NOTE: — This is *not* a throttle cable adjuster. It is a throttle stop screw only.

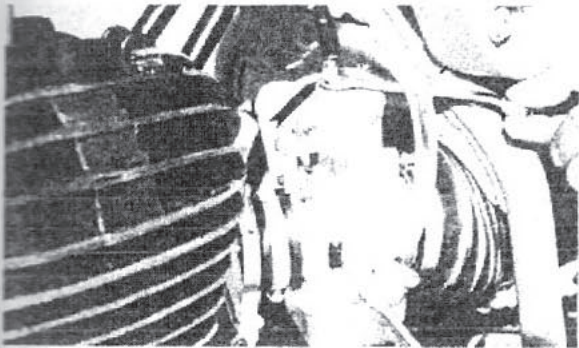

3. All throttle cable adjustments should be made at the top of the carb. There should be about 2mm free play in the throttle cable. NOTE: — When adjusting the throttle cable, make sure the idle screw is completely backed off.

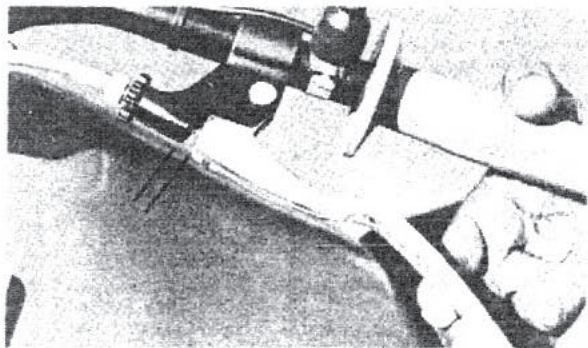

4. The clutch should have about 3mm free play at the pivoting joint.



5. The oil level for the transmission and the primary side can be checked by removing the screw in the side case. With proper level, the oil should just barely leak out with the bike level.

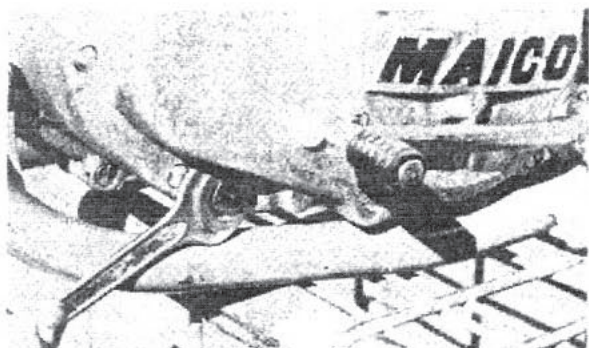

6. To drain the oil, a 17mm wrench is used on the plug at the bottom side of the left case cover. It's a magnetic plug and should be checked for excessive metal, or chips, from damaged primary chains.



7. To add oil, remove the oil filler cap. The gearbox holds 600cc's of oil. Do *not* clean this cap with contact cleaner, as it will cause the plastic to deteriorate.

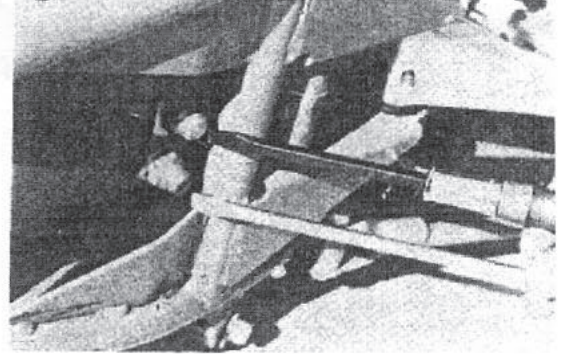

8. *Never* drain the oil by removing either of these plugs or the bottom of the case. One is a cam detent and the other is a shifting cam guide.

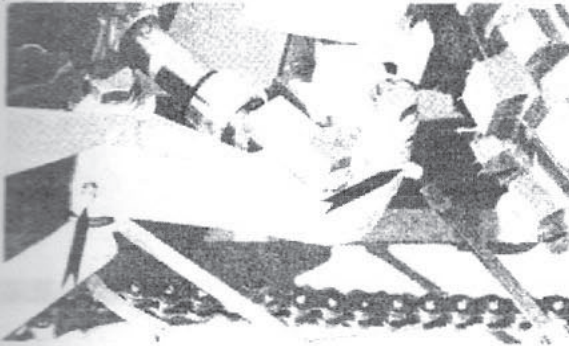

The rocker links on the suspension can be lubed by pumping grease in at the zerk fittings. Periodically, the linkage should be taken apart and examined for corrosion and wear.

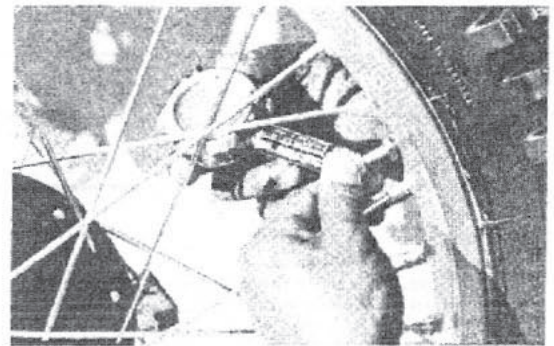

10. Tire pressures should be checked regularly and varied to suit the track conditions. Maicos come with Metzeler tires, either two-ply nylon or four-ply rayon. Both are excellent. Always run at least 15 psi of air in the two-ply tires. These can be identified by the 2E mark on the sidewall. The four-ply tire bears a 4E marking and lower pressures can be run. Most riders use 10 to 12 psi minimum. Always check the pressure with the wheel in the air (unladen) and the tire properly warmed up. A cold reading will always be less than a hot reading.

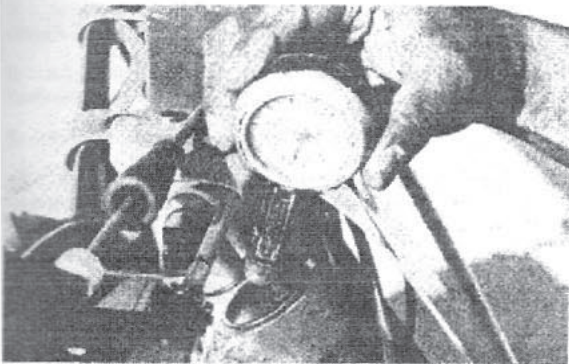

11. Air pressure should be checked after each moto, or as needed, depending on track conditions. Tuning of the forks is covered thoroughly in the fork tuning guide section. Always check the fork air pressure with the front wheel in the air and make sure that both legs are equal.



12. Adjust spokes as needed. Pay particular attention to the spokes during the first few hours of operation. They should be checked every 15 minutes at first, then every half hour after the first few hours, then after each race once they have bedded in. Do *not* overtighten, or tighten in an uneven pattern.



13. The shift lever can be rotated up or down, as preferred, on its splined shaft.

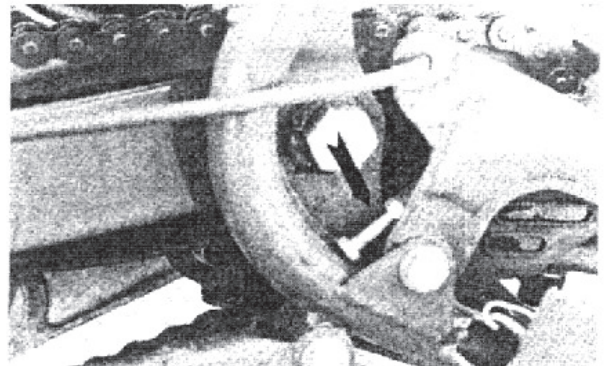

14. The desired brake pedal height can be achieved by adjusting the small bolt at the rear of the brake pedal. Make sure the jam nut is tight.

15. Chain adjustment is covered thoroughly in the section on Rear Wheel Disassembly and Service.

Pre-ride Check List

BASIC MACHINE OPERATION PRE-STARTING CHECK-OUT

1. — Fill the tank with fuel, making sure that the proper gas/oil ratio is used.
2. — Check the transmission oil level.
3. — Make sure that the spark plug is properly tightened.
4. — The filter must be serviced and properly oiled.
5. — Make sure that the throttle returns easily and the throttle action is smooth and positive.
6. — Check all controls for smooth operation.
7. — All nuts and bolts on the machine should have been checked for proper tightness.
8. — All cables and controls must be routed properly and function smoothly.
9. — Brakes must be properly adjusted.
10. — The machine must be mechanically sound and set up according to this manual.

3. — On the 490, the compression lever should be used. There is no compression release on the 250. Fold out the kickstarter and kick sharply, making sure the bike is in neutral. Follow through on the kick. When starting cold, the throttle should be closed. When the engine is hot, full throttle and no tickling, or choking, is recommended.

4. — The engine should fire up at this point.

5. — If your carburetor is equipped with a choke lever, raise it after 20 to 30 seconds. Do not over-rev engine when warming up. It's best to run the engine at a fast idle until the fins are too hot to touch with a bare hand. Riders who fire up a cold engine and immediately start to ride the bike aggressively will drastically shorten engine life. Tests have shown that a properly warmed-up engine will yield a greater life span than one that's never been warmed up properly.

6. — After the engine has been fully warmed up, the throttle can be snapped open and closed a few times to assure proper response.

STOPPING THE MACHINE

STARTING

1. — Open the fuel petcock. Straight down is open, pointing out from the machine is reserve and pointing in to the center of the machine is off.
2. — Flood the carburetor by pressing the tickle button until fuel overflows the carb and comes out the overflow tubes.
3. — Run the engine for a half-minute or so. This will lower the gas level in the carb float bowl.
4. — Let the engine fall to a slow idle, then press the kill button.
5. — The engine will stop running.

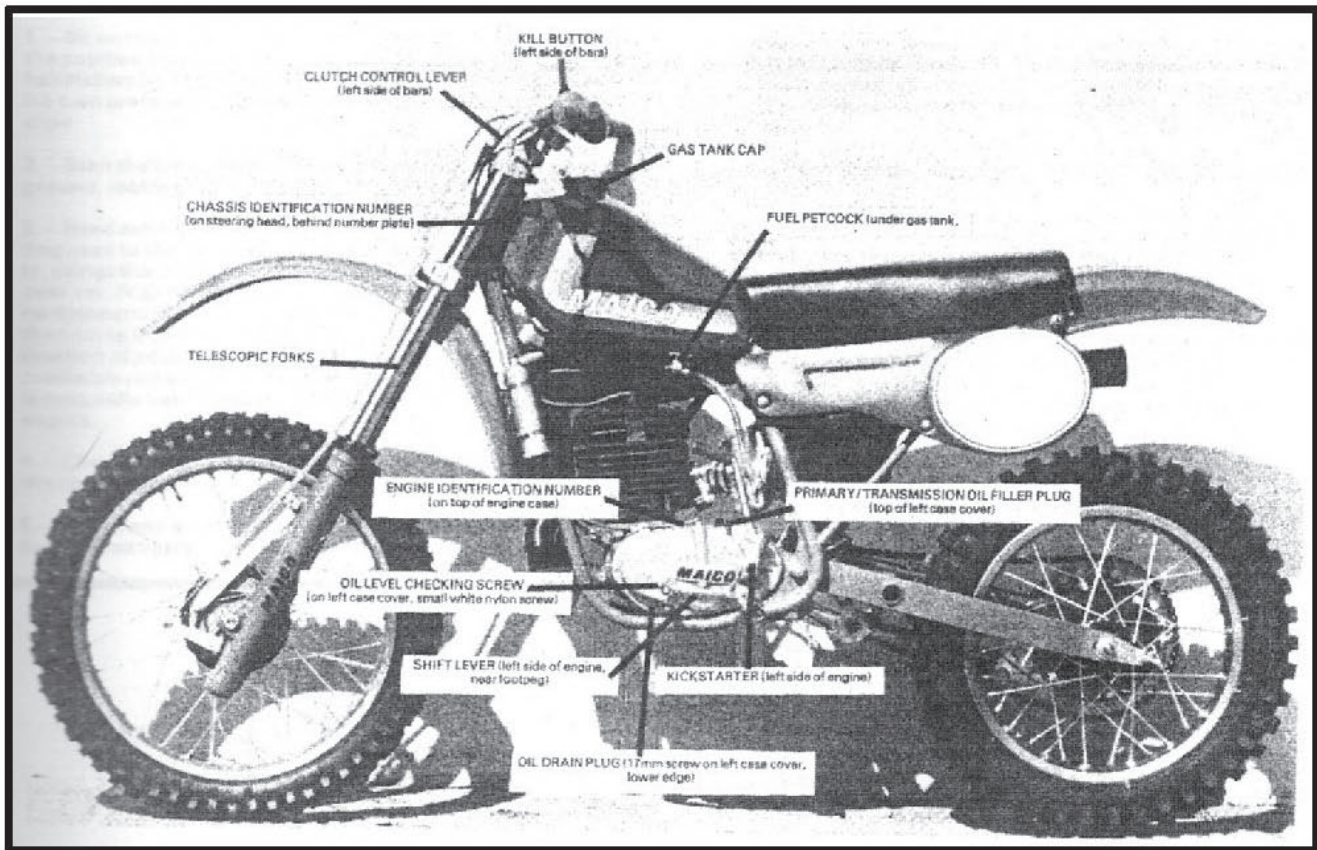

MACHINE FAMILIARIZATION

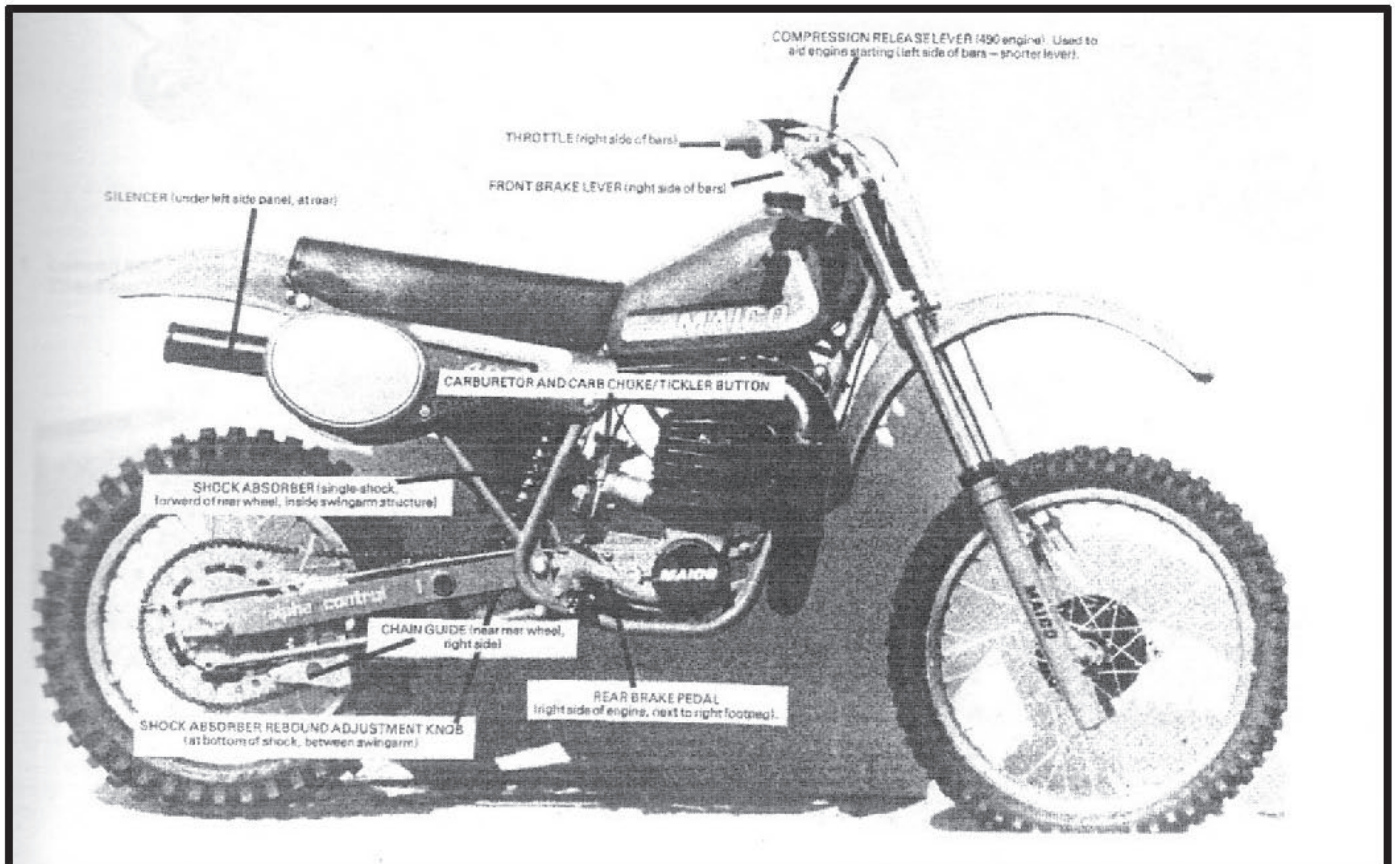

YOUR FIRST RIDE: BREAKING IT IN

1. — Sit on the machine and position the controls and bars in the position that suits you best. Some riders will shorten the handlebars by an inch or more on each side. Each rider has his own preference. Adjust the brakes to suit your riding style.

2. — Start the bike, warm it up and ride carefully on level ground, making sure that all controls function properly.

3. — Head out to the track and take a few very easy laps, getting used to the traits of the machine. Change gears smoothly, using the clutch and don't force the machine to lug, or over-rev. Ride for 20 minutes or so, making sure that there is no detonation or pinging (a sign of too-lean carburetion), then come into the pits and examine the spark plug for an indication of jetting. If the plug shows a too-lean reading, immediately richen the jetting to prevent engine damage. This is especially harmful during the critical break-in hours of any engine.

4. — Check all nuts and bolts, paying particular attention to the engine mount bolts and the swingarm pivot bolt.

5. — Check and adjust all spokes. Spokes have a tendency to come loose easily in the first few days of machine operation.

If you take the time to adjust the spokes frequently during these critical seating-in periods, the wheels will give a long, reliable life-span. If you let the spokes get loose during the break-in period, you may have wheel and spoke problems for the duration of the bikes' racing period. This is important.

6. — Check the sprocket (rear) bolts every time you check the spokes.

7. — Make mental notes on how the forks and the rear suspension function. Don't make any major adjustments during the early break-in hours, as new seal friction can be misleading.

8. — As you get used to the bike, the throttle can be opened up more and more. Don't let the bike get too hot, or run it very hard for the first few hours. It's a good idea to put two or three tanks of gas through the bike at moderate stress conditions until everything seats in.

9. — During the initial break-in hours, it's a wise idea to drain the gearbox oil out after every few hours of operation. In fact, many smart professional racers drain out the hot gearbox oil after every riding session, thereby assuring long and reliable gearbox and primary chain life.

Air Filter, Service and Procedure

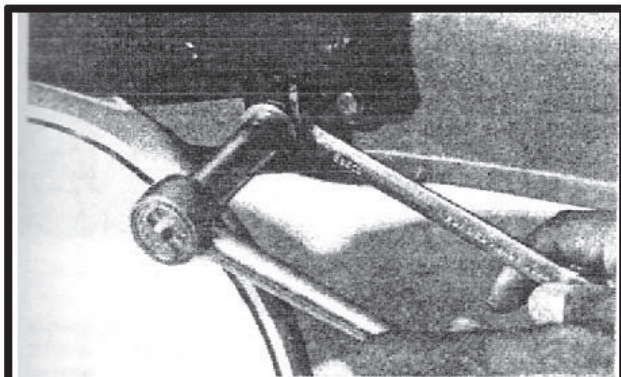

1. Loosen and remove the bolts holding the seat in place. There are two 13mm nut/bolts at the rear of the saddle.



2. Remove the saddle and clean the underside of the seat base with soap and water.



3. Squeeze the wire rods that hold the filter in place, then lift out the rod. Set it aside and clean it.

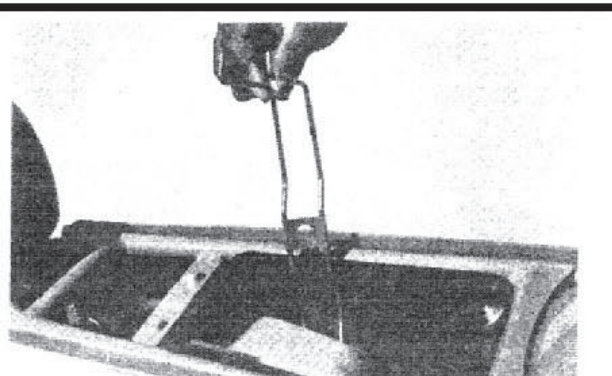

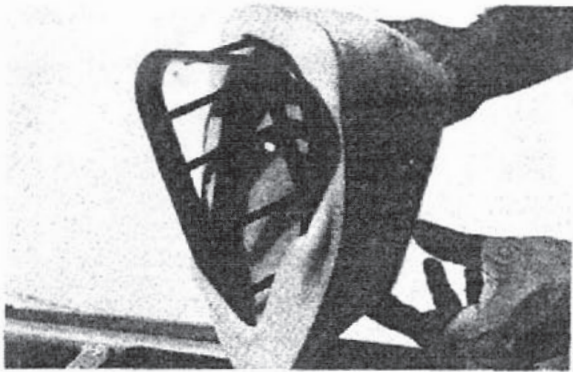

4. Remove the filter from the still airbox and remove the foam filter from the plastic filter cage.

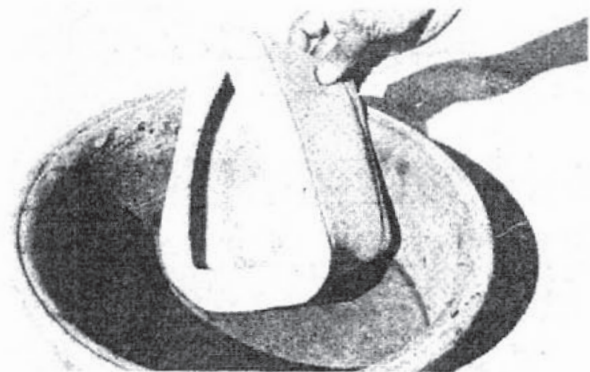

5. Wash the filter in a clean solvent. Do *not* wash it in gasoline. Not only is gasoline very toxic (it can be absorbed into the bloodstream through the skin), it also attacks the glue that holds the filter together. In time, it may cause the foam to separate at the joinings. Next, wash the filter thoroughly in soap and water. Any liquid soap will do the job just fine. Rinse and wash the filter several times, making sure that you get all the grit, dirt and sand out. Let the filter air dry.

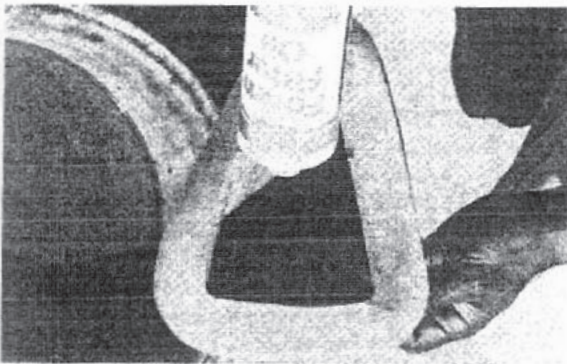

6. Oil the filter in a good filter oil, or lacking that, use SAE 20 gear oil. Saturate the filter thoroughly, then gently squeeze the excess oil out. Make sure that there are no dry spots in the foam.

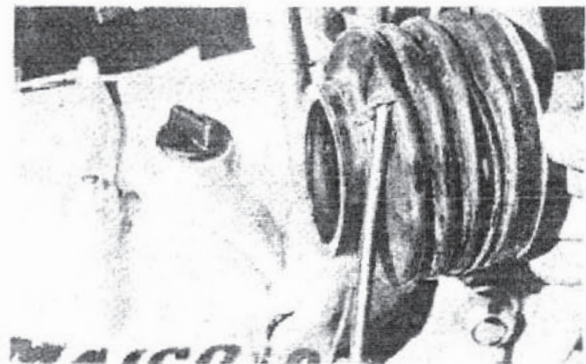

7. At this point, check the air box for general cleanliness and clean the area where the filter will rest. Check the rubber boot between the carb and the air box for dirt, or excessive oil buildup. Also, check the boot for any signs of cracking or splitting.



8. Put the filter back over the plastic filter cage. Lightly grease the face of the filter that will rest on the air box. Bel-Ray wheel bearing grease works well.

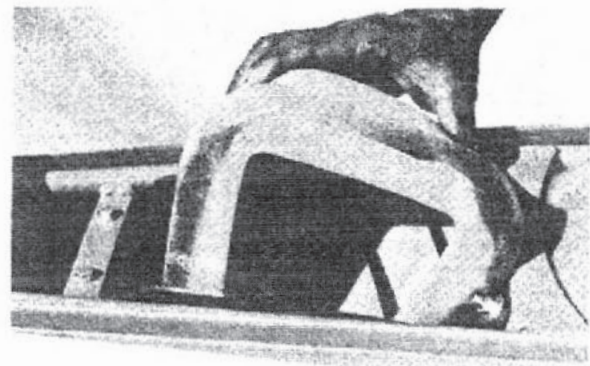

9. Seat the filter properly on the flange.



10. Reinstall the holding wire and make sure the filter is properly seated. Reach in the air box and feel all around the filter edges.

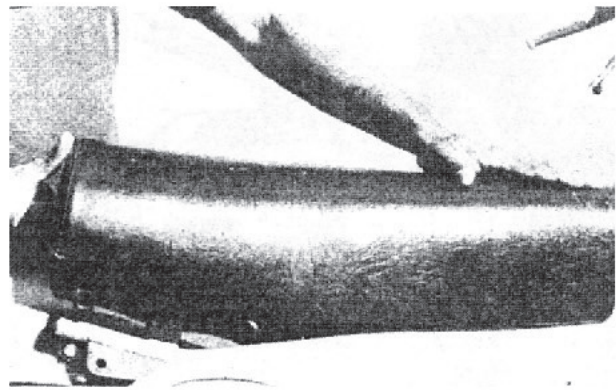

Carburetor and Jetting

CARBURETION AND JETTING

The function of a carburetor is a simple one: it merely has to mix 15 parts of air to one part of gas (by weight). Complication sets in when one realizes that a racing engine does not run at one constant speed. The engine must run efficiently from idle to peak rpm. To get a proper ratio of air-to-gas throughout this range, there must be several circuits in any carburetor.

LOW SPEED

At low engine speeds, the pilot jet controls most of the operation. It's also very important in starting the machine. If the pilot is too small, insufficient gas will make it difficult to fire up the machine, especially when it's cold. A hot engine will often start on a too-lean pilot, because of the presence of gas vapors in the engine. A too-rich pilot jet will readily start a cold engine, but will make the engine blubber and smoke heavily when the engine gets warm.

MID-RANGE

At mid-range speeds, the needle jet and the needle do most of the work. They control anything above a fast idle all the way up to about three-quarter throttle. The cutaway on the slide also controls mid-range functions, but this should not have to be altered under normal racing conditions. Most needed jetting changes can be achieved by adjusting the needle position and the size of the needle jet.

HIGH RPM

The main jet affects high revs. When the throttle is wide open, the main jet is doing most of the work, but the pilot jet will still contribute a few percent to the overall flow of the carburetor. This is why a clogged pilot jet can make a properly jetted bike seize at full throttle conditions.

JETTING BASICS

Most people will not hesitate to jump right in and change the main jet on most any carburetor to correct any and all ills. This is wrong. Let's assume for the moment that your carburetor is completely out of the ballpark. Where should you start?

Well, why not start at the beginning? That's right... get the pilot circuit dialed in first. Make sure the bike will start easily and run reasonably well right off the bottom end of the rpm range.

A properly jetted bike should fire within three kicks all of the time and on the first kick most of the time. An overly rich pilot jet will let a cold bike fire up easily, but the bike will blubber and smoke when it's warmed up.

The jetting chart in this manual shows you the basic jetting. In most cases, it will be remarkably close to what's needed. For example, the pilot jet indicated for a 490 Maico is a 50. You should not have to go more than one jet size in either direction to get optimum performance. In other words, a 55 or a 45 pilot will more than likely supply your needs. Colder and low altitude areas will require a richer pilot. High altitude and hotter areas will require a leaner pilot. The larger the number, the richer the pilot. Example: a 55 is richer than a 50. The same applies to all numbers in the Bing jetting system.

OVERLAPPING CIRCUITS

Jetting is not cut and dried. All of the jetting circuits overlap to some extent. Thus, a change in the pilot jet will have an effect on the early part of the mid-range performance and so forth.

It's always safe to be slightly on the rich side, if in doubt about jetting. This can prevent expensive seizures. The jetting ritual should start with the pilot, then the

tuner should select the right needle jet. After low-end and mid-range response is good, then the main jet can be selected.

DETONATION AND PLUG READINGS

Two of the most reliable indicators of correct carb jetting are reading the spark plug and listening for pinging, or detonation. Detonation is a rattling sound that accompanies a "too-lean" engine under a heavy load. It's called the death rattle by savvy tuners and racers. This must be avoided at all costs. A slight detonation at mid-range rpm can be tolerated, and, in fact, some Grand Prix riders tune their bikes on this ragged edge for maximum power. But, for safety sake, never allow detonation to occur at high rpm, or consistently under a heavy engine load at any rpm.

Your spark plug can also reveal what's happening inside your engine. Basically, a black and oily plug indicates the bike is jetted too rich. Before each reading, the plug must be cleaned, or a new plug installed. An old plug will give false readings.

It's also difficult to get a clear plug reading with many of the new synthetic oils on the market. Initial jetting should be done with a "normal" petroleum-based two-stroke oil of good quality. If you want to switch to a synthetic after the jetting, that's fine. But dial the jetting in with a standard oil.

THE BING CARBURETOR

Exhaustive tests at the Maico factory have shown that the Bing carburetor produces more horsepower per millimeter of bore than any other unit available. The Bing breather is also a very simple mechanism, with a quickly detachable float bowl for cleaning and servicing.

Like any carburetor, the Bing must be kept clean internally and inspected regularly for wear in the slide and needle/needle jet areas. When dealing with the sizes in jets and orifices, one must talk in terms of half-thousandths. Any wear at all could cause erratic behavior in performance, or engine failure.

JETTING CHANGES: WHY?

Simple. A Maico is built, designed and tested in Germany. The machine might end up racing in Colorado, or Australia. The factory sends all bikes out to the customers with "average" jetting. Which means that the bike may...or may not...be right for your altitude. It is impossible for any factory to set up each bike for each particular area.

This is where dialing the carburetor in for your area and needs becomes important. Many people ride a Maico and are very happy with it, even though the jetting may be somewhat off. If they took the time to investigate the needs of their bike for their particular area, they would be rewarded with absolutely superior performance.

Also, because of the inherent difference from one piece of machinery to another, the demands of the engine might be different in the same area and even on the same track. In actual fact, one 490 Maico might be happy with a 185 main jet, while another one will require a 190 for maximum performance. The Maico is a pure racing weapon and must be treated as such. Honing the weapon is sensible and desirable.

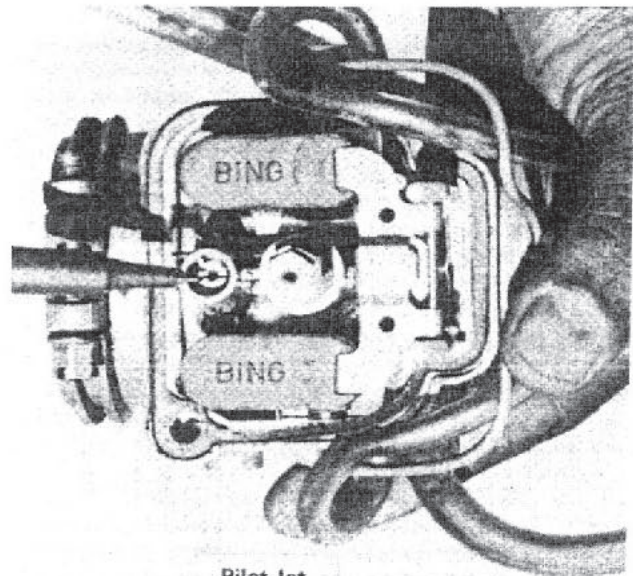

Pilot Jet

JETTING CHART	250cc	490cc
Main jet	195	190
Needle jet	278-2	280-2
Pilot jet	65	50
	60	
Needle	6D2	6L2
Slide	210-3	220
Air screw		1/2 to 3/4 turn
Vaporizer	#7	#3
Needle position		Middle

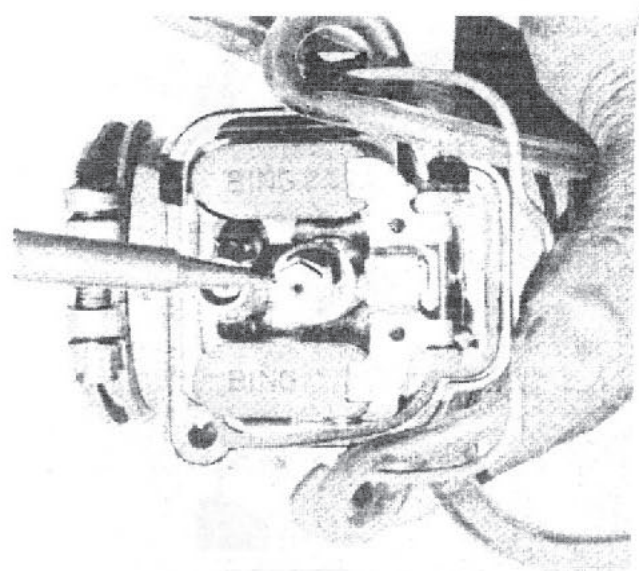

Main Jet

FLOAT LEVEL ADJUSTMENT

The float level should be adjusted so that a constant fuel level is maintained in the float bowl. If needed, the float can be adjusted by bending the hinge up or down to achieve a parallel alignment (see the illustration). The hinge should just touch the float needle, but not compress it, for proper level.

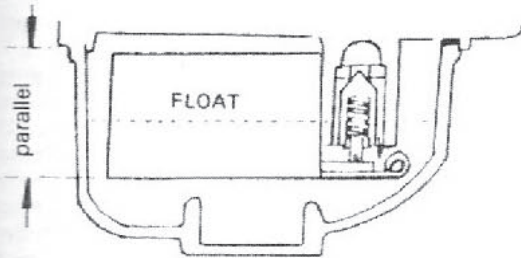

RATIOS CAN AFFECT JETTING

A very common mistake many riders make is varying the gas/oil ratio in their machine. If you have your bike jetted and tuned to perform well on a 20:1 gas/oil ratio, a change to 50:1 will make the bike run appreciably richer. Read that once again. **MORE OIL IN THE GAS LEANS OUT THE JETTING. LESS OIL IN THE GAS RICHENS THE JETTING.**

At first, this seems like a contradiction. But, consider this. The more oil present in the gas, the less gas in relation to the air. The less oil, the more gas. And gas makes power. *Not* oil. In fact, your Maico will probably make more horsepower with the leaner gas/oil ratios. We have found that a 32:1 mix ratio is a good compromise. This produces good power and still gives more than adequate lubrication.

Remember, any time you radically change the gas/oil ratio, the jetting will probably have to be changed to match. This manual recommends certain oils that have worked well for the Maico racing team.

Fork Tuning

MAICO TELESCOPIC FORKS: FUNCTION AND TUNING

Maico forks are specifically designed for high performance, off-road racing. The tubes are hefty 42mm diameter units and are incredibly strong, while retaining light weight. Aluminum fork sliders with low friction seals make up the lower part of the fork assembly.

Front wheel travel is 310mm... or 12.2 inches. This is felt to be the optimum wheel travel for all-around handling and maximum bump absorption. A linear-wound spring is inside each fork tube and these are assisted by using air as a spring.

With the combination of a normal spring and air (or nitrogen), there are almost limitless tuning possibilities with the Maico fork. However, most riders will find that satisfactory performance will be within certain ranges.

For example, our racing team reports that air pressures between the 10 and 14 psi range seem to work best. The average rider would do well to break in his new Maico on the low side of the air pressure adjustment... perhaps 10 or eleven psi of air.

IMPORTANT! Please note that all fork pressure readings and adjustments **MUST** be made with the **FRONT WHEEL IN THE AIR**.

The machine should be placed on a box, or stand, and the air valve must be cleaned before applying gauges. For this reason, it's advisable to use the air fitting covers that are supplied with the bike. At no time should unequal pressure be allowed in fork legs.

All air-assisted forks will tend to "pump-up" a bit after hard usage over a period of time. That's why it's a good idea to check the air pressure regularly on your racing machine. Smart professional riders do this after every moto. Can you do any less?

NOTE:—While a certain small amount of misting and oil weeping is common and can occur in any fork assembly, heavy oil loss is an indication that the seals are worn and must be replaced. Do not expect top performance from any set of forks that pass large amounts of oil. By large amounts, we mean that anything more than a light film is a problem. If any significant oil loss is realized, it means that there may be an unequal amount of oil in the legs and the action in each leg will be different. The forks will "fight" each other and performance will be markedly lowered.

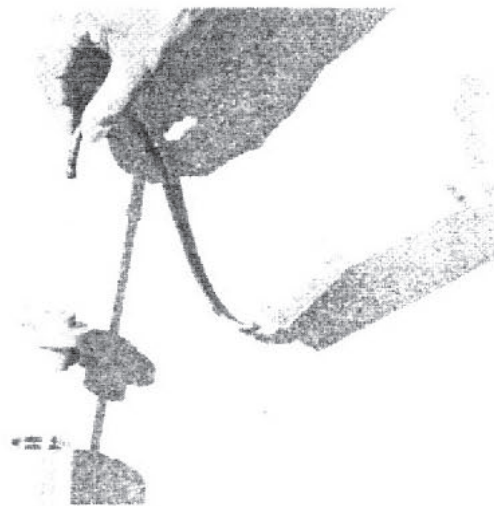

For maximum tuning accuracy, a gauge such as this oil adjuster should be used.

To review, the following facts must be considered:

1. The forks must be in sound mechanical condition, with good seals and no scratches, nicks or pitting in the fork tubes.
2. There must be the same amount of oil in each fork leg and it must be the same type, brand and viscosity. One 5 weight oil, for example, can be slipperier than another 5 weight oil.
3. You must have the same air pressure in each fork leg. Variance of a half-pound is the limit.
4. Try to use the same air gauge all the time and make sure it's of decent quality. You'll be amazed at the variance in the readings from one gauge to another.
5. Only make adjustments in pressure, or oil level, in small increments and only make one change at a time. Do not change the oil level and the air pressure and expect to know which function caused what to happen to the fork action.
6. Keep notes in your manual on what pressures, oils and levels you have used at various tracks. There is room in the Maico manual for such notes. They can be a valuable aid to the serious racer.

FORK TUNING GUIDELINES: OIL LEVEL AND TYPE

Do not use automotive oil, or automatic transmission fluid in your forks. Use only a high-quality fork oil with a designated SAE grade clearly indicated on the can or bottle. Avoid oils that are labeled "light" or "medium," rather, use specific grades such as five weight or ten weight.

The recommended starting oil level is 535cc. The factory recommends 5 weight, or LT100. You may want to check the oil level, in addition to just pouring in 535cc's of oil, as slight differences in internal dimensions can cause a small difference in the actual oil level.

To check the oil level properly, the fork air caps must be removed.

CAUTION! ALWAYS BLEED ALL THE AIR OUT OF THE LEGS BEFORE ATTEMPTING TO REMOVE THE CAP.

Next, remove the fork springs and set them aside in a clean area. The forks should then be slowly compressed until they bottom completely. If you do not have a friend to aid you, a simple tie-down can be hooked to the front axle and the handlebars and drawn tight. The actual level of the oil can be measured with a ruler, or a special oil level gauge. Simons Inc., makes a simple, inexpensive unit that not only measures the oil level, but can suction excess oil out.

The volume of air in the legs has a dramatic effect on how and when the forks get stiffer. Basically, the smaller the air space (more oil), the firmer the forks will get from mid-stroke on down. It's best to try to get the fork action you want with the minimum air pressure.

Example:—Let's say you have an oil level of 6.7 inches, with 5 weight oil and you're running 10 pounds of air. The forks feel good on the small and medium bumps, but bottom a bit too much over the worst bumps on the track. If you raise the air pressure a few pounds and this does not cure the bottoming problem, then it's best to raise the oil level a half-inch at a time. This way, you can keep the action of the forks soft and responsive on the small and medium bumps, while the forks will firm up appreciably on the really bad ones.

Do not resort to an overly heavy fork oil to correct a bottoming-out situation, as the forks will then become insensitive to sharp-edged bumps. An ideal set of Maico forks will absorb stiffer bumps well, yet will not make a harsh metal-to-metal contact when fully stroking.

Use the following as a guideline:

1. Start your fork tuning with 10 psi of air and the basic recommended fork oil level.
2. If the forks are too soft, add a few pounds of air.
3. If this does not prove satisfactory, then return to the 10 psi level and add ½-inch to the oil level in each fork leg.
4. If the action is still too soft, add two pounds of air and try again.
5. You can keep adding oil until the fork starts losing travel. This can be checked by making a mark on the fork leg and wrapping a zip-tie around the leg and checking its' position after a few hard practice laps.
6. If the action is too stiff, go the opposite direction and reduce the oil level in small increments.
7. Never exceed 15 psi air pressure. By experimenting, you can find the right oil level, viscosity and air pressure for just about any conditions you might encounter.

NOTE:— FORK ACTION CAN AND WILL ALTER HANDLING CHARACTERISTICS.

Be advised that the different fork action will change the way the bike turns and handles at both high and low speeds.

As a guide, softer forks will allow the front end to settle easier and make the turning quicker. There is a trade-off, though, as some high-speed stability may be sacrificed.

Conversely, a firm fork action will slow down the turning quickness of the bike. This may be desirable on very high-speed courses, such as cross-country, or desert racing. The racer must be aware of this and tune his forks to his needs.

Some additional adjustments can be gained by raising and lowering the fork tubes in the triple clamps. At no time should the forks be raised more than 11mm above the top surface of the triple clamp, as the tire may then make contact with the fender, creating a condition of potential front wheel lock-up. For the "average" motocross track, most successful Maico racers run the fork tubes raised up about 1/3-inch above the clamps. Most desert and cross-country racers run the tubes flush (fully extended) with the top of the triple clamps.

By using all of the above available techniques, the intelligent racer can quite literally dial his forks in to meet the demands of any track he may encounter. Patience, experimenting and careful observation are all that's needed to perfect the world's finest forks. Take the time to make your Maico forks suit your riding style and skill level. The rewards will be obvious and will give you an edge over the competition. This is the way professional tuners dial in the forks for factory racers. Can you settle for anything less? Of course not! That's why you bought a Maico in the first place. Let average riders ride average bikes with average forks. The Maico rider can be secure that his equipment is state-of-the-art.

Fork Disassembly

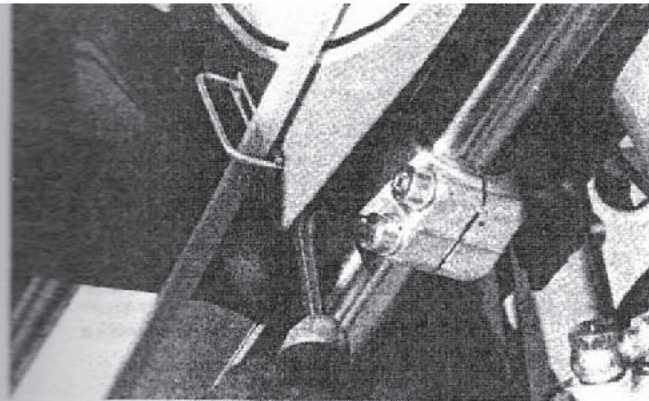

1. Remove the front wheel and backing plate. (See the section on front wheel removal for details.) Loosen the allen bolts on the top and bottom triple clamps.

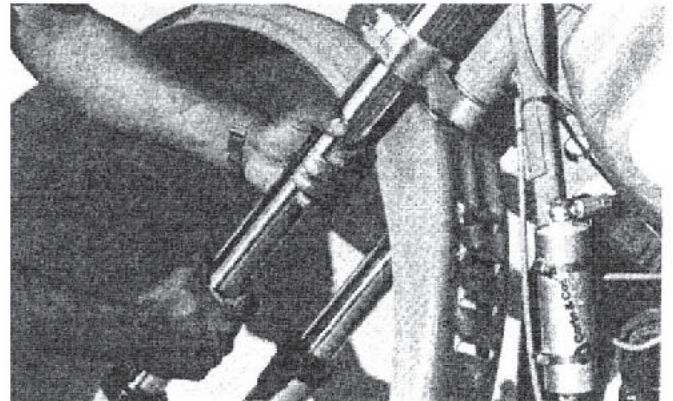

2. Grab one fork tube at a time and, using a twisting motion, pull the tube down and out of the triple clamps.



3. Remove the valve cap and let the air out of the air fitting. **CAUTION! ALL THE AIR MUST BE OUT OF THE FORKS BEFORE ANY FURTHER DISASSEMBLY.**

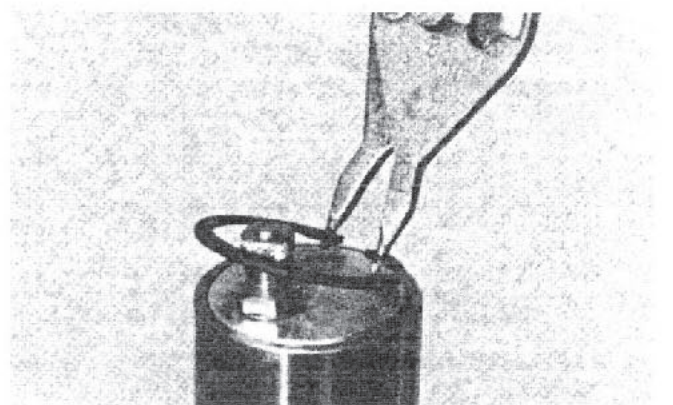

4. Remove the circlip holding the fork cap in place. Be sure to press down on the cap as the clip is being removed to keep the cap from springing up.

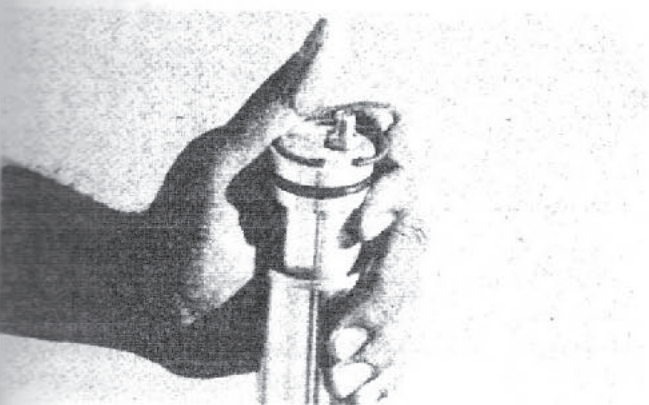

If the cap does not immediately pop free, push down lightly on the fork tubes and the pressure of the internal spring will lift the cap free.

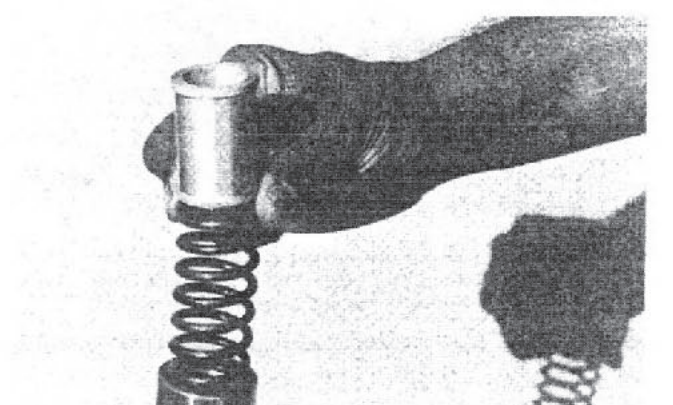

6. Remove the spacer and the fork spring. Set them aside.

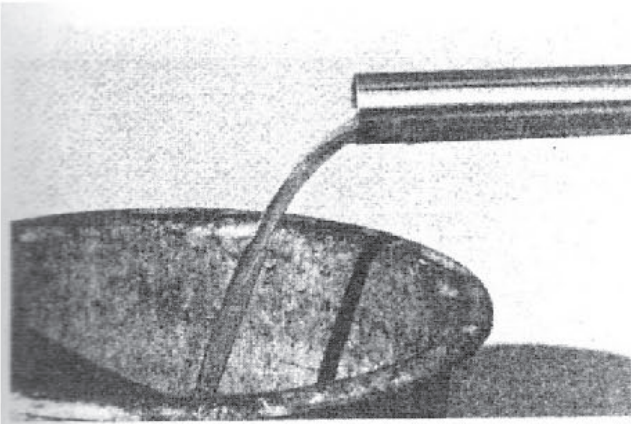

7. Turn the fork assembly upside down and drain the oil out in a drain pan. After most of the oil is out, pump the fork up and down to remove any trapped oil. Let the fork sit upside down for a few minutes to drain it out completely. Flush the fork out with a solvent. This makes disassembly a cleaner job.

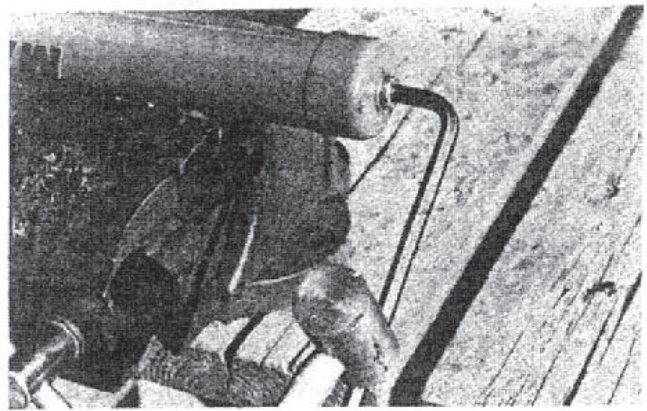

8. Hold the lower fork leg in a vise at the axle tabs; insert an allen wrench in the allen bolt in the bottom of the fork leg and screw it out. If the allen bolt turns and does not loosen, a sharp rap with a soft mallet on the allen wrench will normally free the allen bolt.

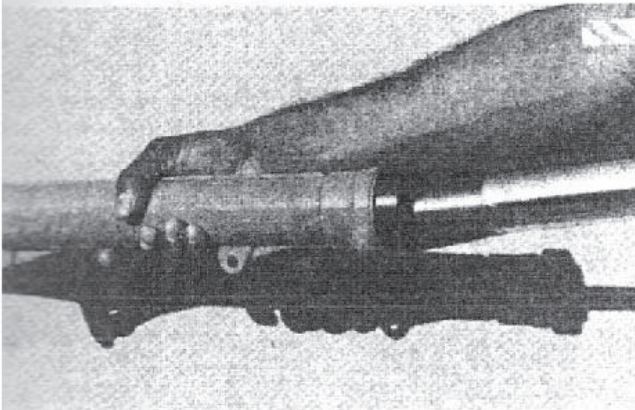

9. Slide the fork tube carefully out of the lower leg. The damper rod will stay in the fork tube.

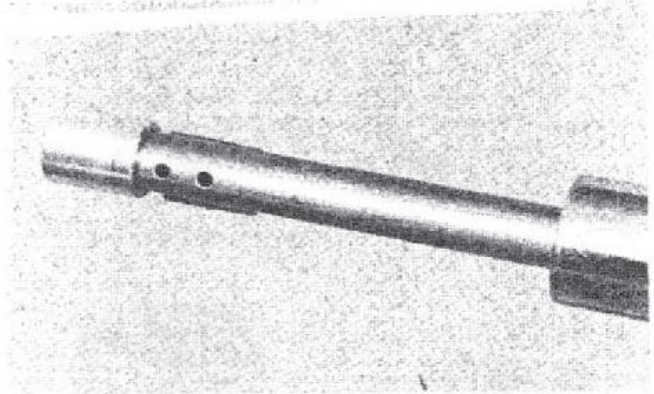

10. At the bottom of the damper assembly is an aluminum piece. Pull that off, then turn the fork tube upside down and let the damper rod gently slide out. Catch it in your palm.

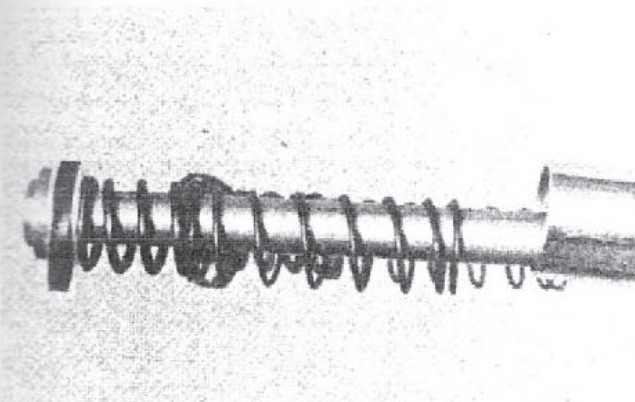

11. If the fork tube has to be changed (very rare, as the Maico features a super strong 42mm chromoly steel tube), don't forget to take the valve, the valve seat and the damper insert out. For normal cleaning and mainten-

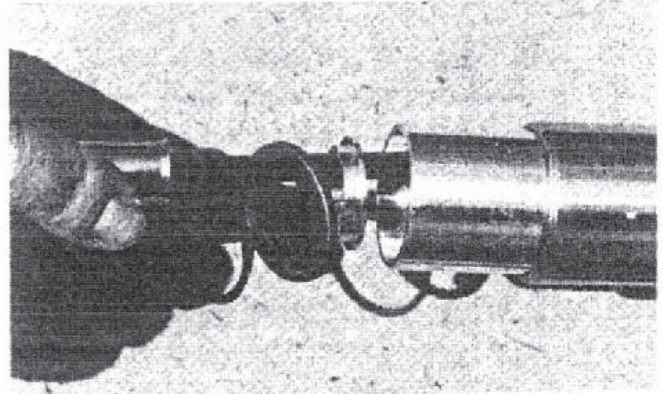

ance, leave these intact in the fork tube and no service is required. Clean all parts, including the damper rod assembly and blow all of the holes out with compressed air.

INSPECTION OF FORK PARTS

1. Check carefully to see if the fork tubes are bent. This can be done by slowly rolling the fork tubes on a perfectly flat surface, such as a sheet of glass. Or, a true straight edge can be laid against the tubes.

2. Insert the fork tube in the slider and move it slowly up and down. Check to see that the action is smooth. Rotate the tube $\frac{1}{4}$ turn and check it again. Repeat until 360° of rotation have been completed.

3. Examine the fork tube for scratches, nicks or pitting. In case of damages, replace the fork tube.

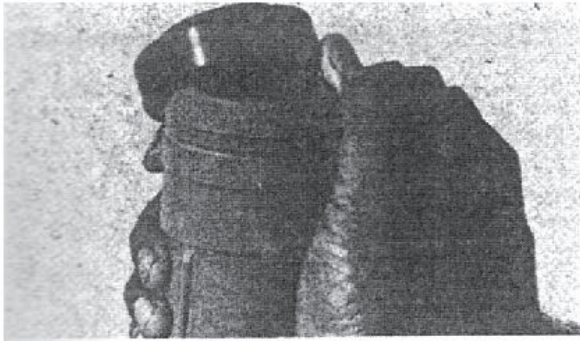

1. Remove the fork seal wiper. This can be lifted off with a twisting motion.



2. Remove the ring that holds the seal in place. Use a screwdriver.

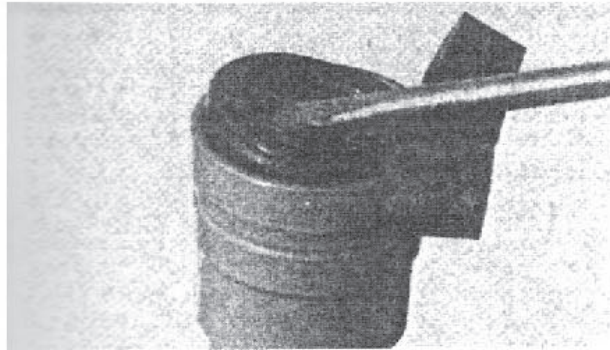

3. Gently lift out the fork seal with a flat bar. It's best to place a piece of rubber, or wood, between the extracting tool and the top of the fork leg.

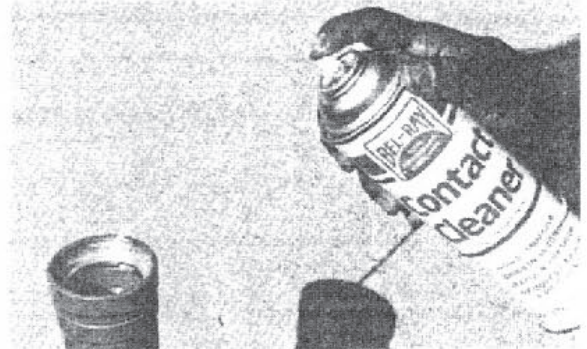

4. Clean the inner surface thoroughly.



5. Press in the new fork seal by hand. If needed, the seal can be tapped in by hitting a punch on the outer edge of the seal.



5. Insert the ring, making sure it's seated properly. Lightly grease the lips of the seal. Wheel bearing grease can be used.

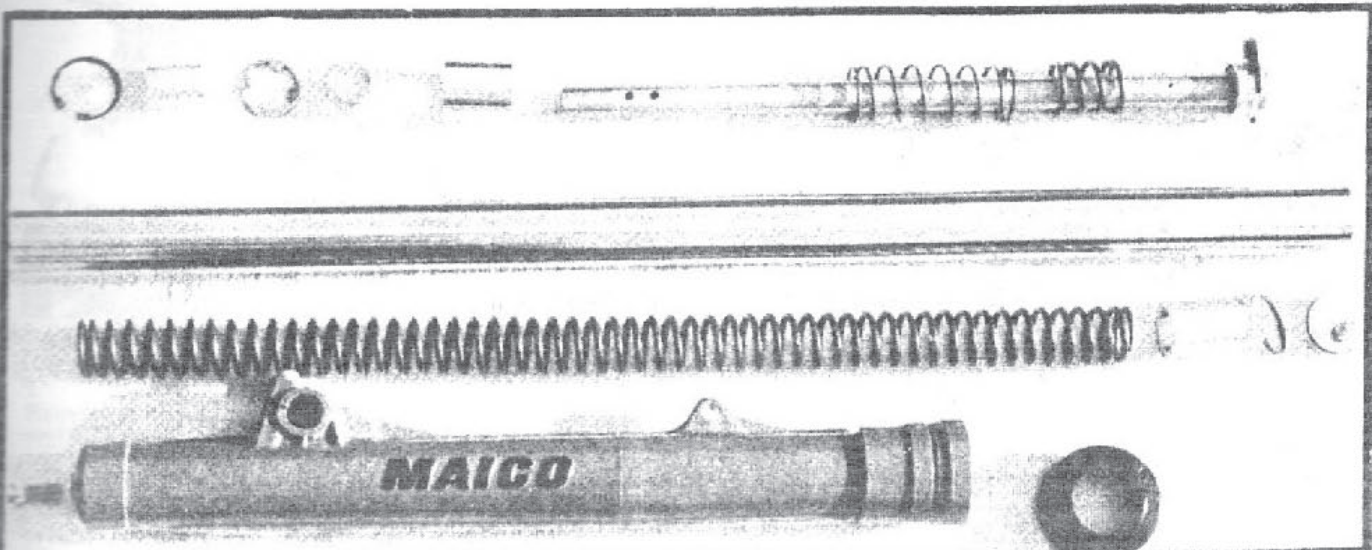

FORK ASSEMBLY

1. Make sure that all parts are clean and free of grit before reassembly.
2. Install the damper rod into the fork tube.
3. After the end of the damper rod is through the fork tube, the tapered aluminum slug should be slipped in place.
4. Carefully slide the fork tube (with the damper rod inside) into the lower fork leg. Use a slight twisting motion to prevent damage to the fork seal.
5. When the damper assembly bottoms out in the lower fork leg, the allen bolt can then be inserted by hand and partially tightened. Then, the allen wrench can be used to tighten the allen bolt fully. Again, it may be necessary to tap the allen wrench with a mallet to get the allen bolt to seat and lock into place.
6. After the allen bolt has been secured, remove the lower fork leg from the vise and work it up and down to assure that the action is proper.
7. Pour in fresh fork oil. Please note the fork tuning section for levels and oil viscosities. Work the fork up and down gently to get any trapped air out.
8. Insert the spring and spacers.
9. Press the fork cap in and seat the circlip. Rotate the circlip to make sure it's properly in place.
10. Fill the fork with the correct air pressure. Again, refer to the fork tuning section for variables available. Replace the valve caps.
11. Reassemble the forks in the opposite manner of disassembly.

Steering Head Disassembly

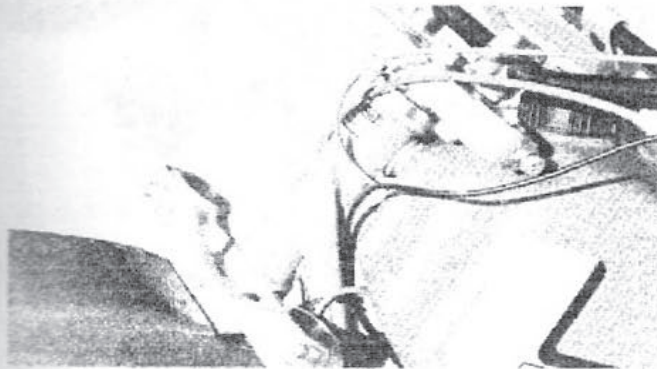

1. Remove front wheel and forks. See fork section for details.

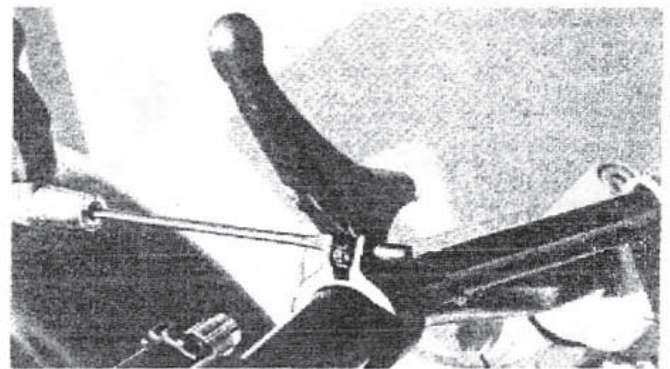

2. Remove decompressor (490 only) by slipping out the split pin, rather than removing the cable end. With the pin out, the cable end stays intact and the lever can be rotated out of the joint.



3. Remove bars and all controls, front numberplate, cables and kill button.



4. Front fender can be removed at this point. Four 10mm bolts hold it in place.

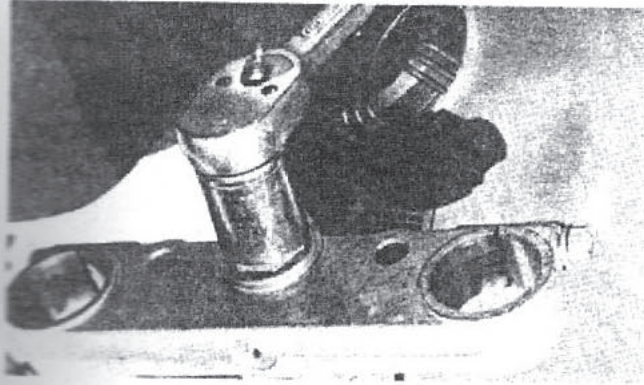

5. Loosen the top center triple clamp pinch bolt and then loosen and remove the 27mm bolt on the steering stem.

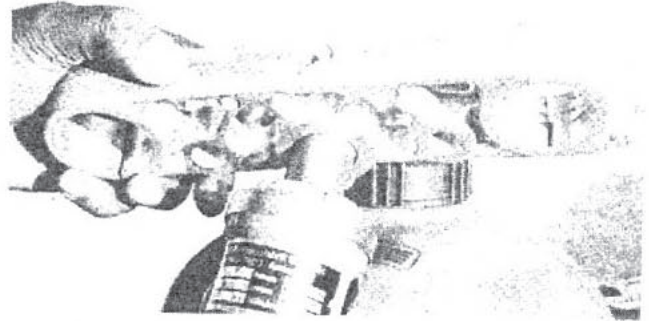

6. The top triple clamp can be tapped free and removed now. Use a rubber or lead mallet.

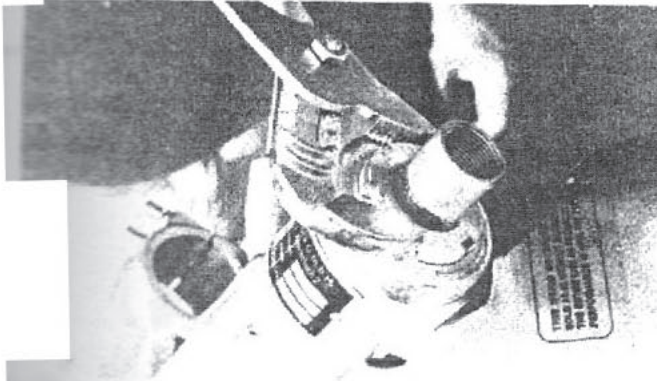

7. Remove the steering head jam nut.

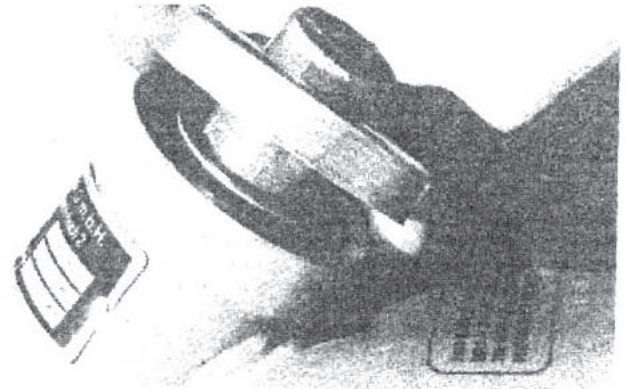

8. Lift off the top dust cover.

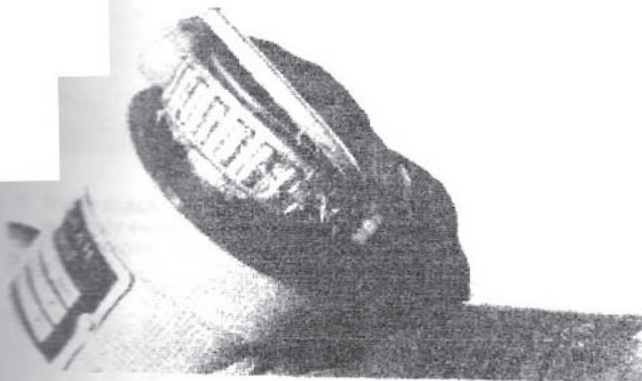

9. Remove the top tapered bearing and bearing dust cover.

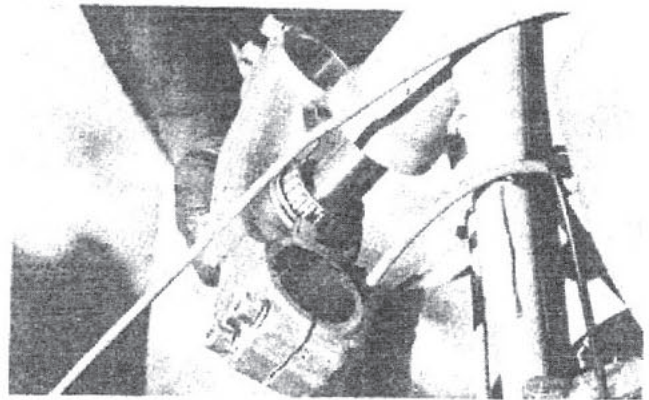

10. Lower the bottom triple clamp out of the steering head. Do not let it drop.

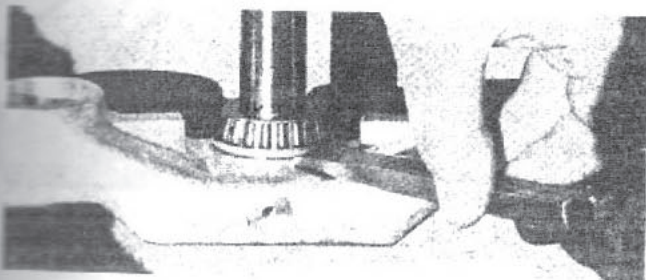

11. If the tapered bearing must be replaced, it can be carefully tapped out with a chisel. Work lightly from side to side with easy taps. If the stem needs to be replaced (if it was bent in a bad crash, for example), the lower clamp must be heated with a torch before the stem is pressed out. When pressing a new stem in, heat must also be used.



12. If the top race is worn, it can be tapped out with a long drift.

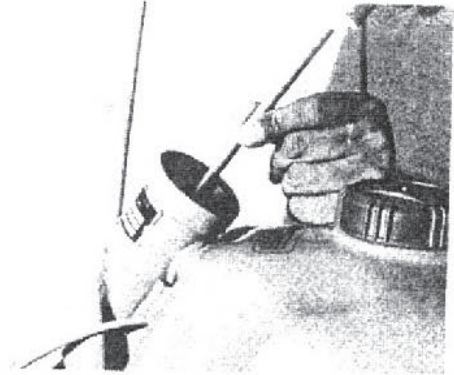

13. Likewise, the bottom race can be tapped from the top and removed. To replace races, merely tap them solidly home with a suitable tool.

Reassembly

Reverse the process to reassemble. Clean all parts and grease liberally. Adjust free play with loose triple clamp bolts, then tighten after adjustment.

Front Wheel Disassembly

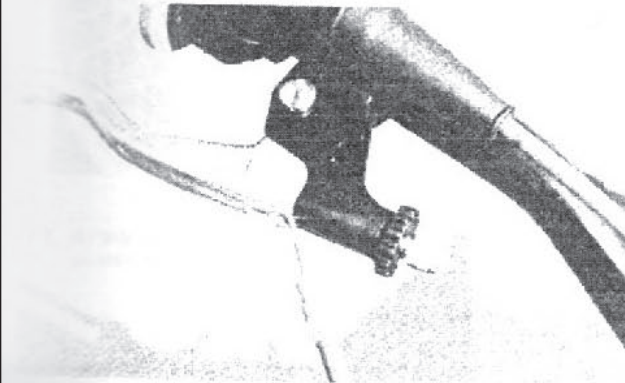

1. Raise machine off the ground. Use either a workstand, or a sturdy crate. Make sure that the front wheel is clear of the ground. Loosen the front brake cable at the hand control.

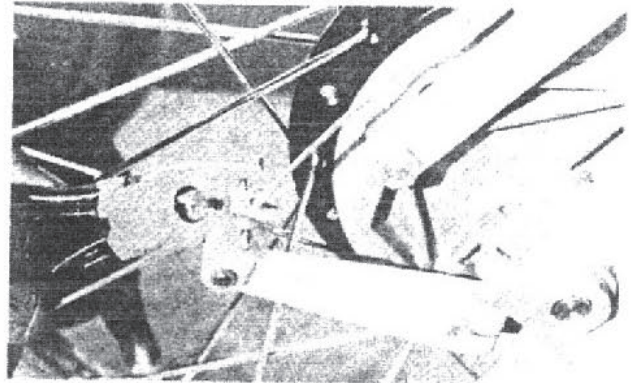

2. Pull the cotter pin out of the brake arm clevis.



3. Disconnect the brake cable from the brake arm.



4. Loosen the 10mm bolts on both fork legs.

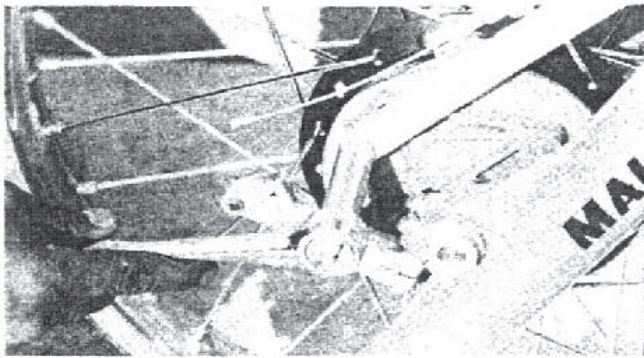

5. Remove the backing plate bolt and loosen the brake stay arm.

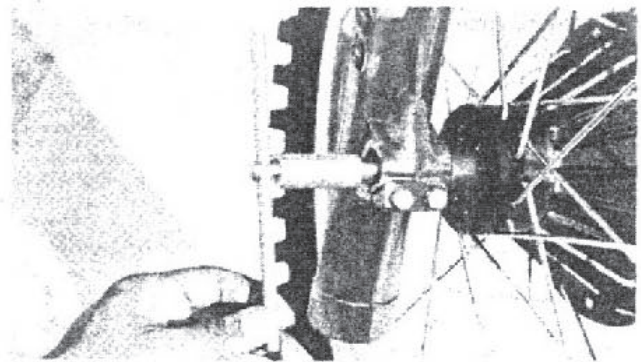

6. The front axle can be pulled out with a twisting motion.

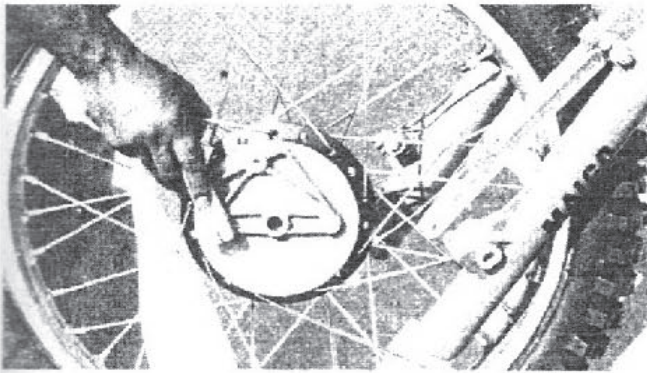

7. At this point, the front wheel can be removed; note the position of all parts.

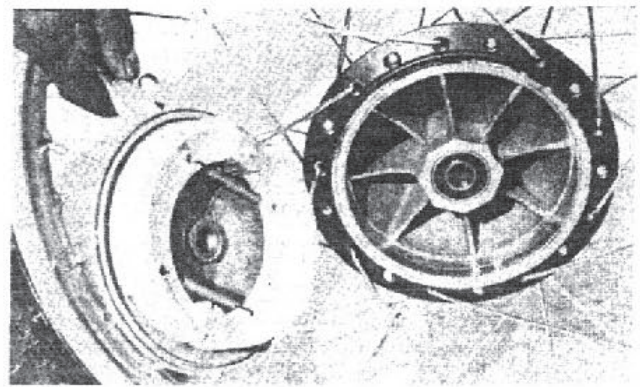

8. Pull the backing out from the hub. The front wheel and the backing plate are now ready for inspection.

FRONT WHEEL AND BRAKE INSPECTION AND SERVICE

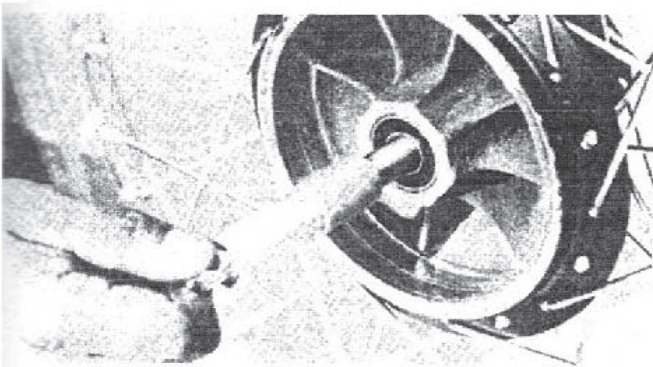

1. Check the wheel bearings for excessive play, or clearance, with the axle inserted.

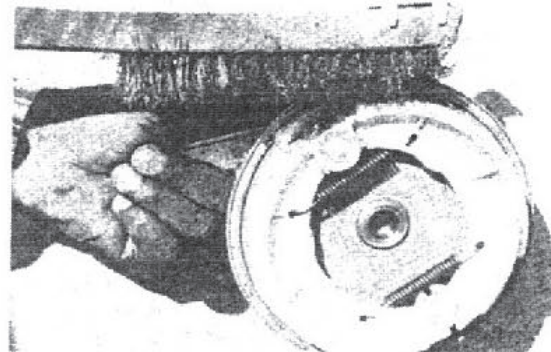

2. Clean the front brake backing plate thoroughly. Dust from shoe wear, combined with dirt, dust and water, will leave a buildup on the inside of the plate. Clean the brake drum lining. If there are signs of rust, lightly sand or wire-brush the lining. Check the brake shoes for wear or signs of cracking. Check the brake return springs for rust or heavy wear at the connections and for resiliency.

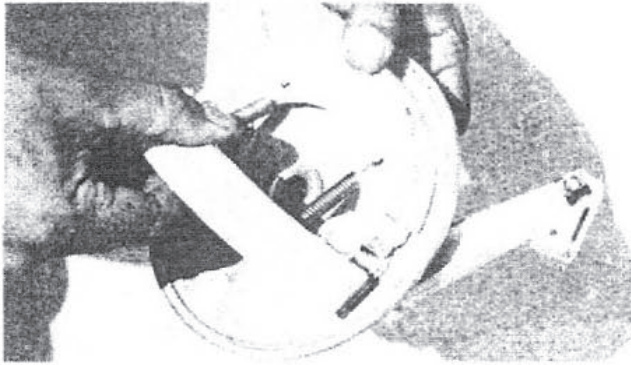

3. Remove the brake shoes from the backing plate. This can be easily done by grasping the outer edge of the shoes and lifting up. Do not pinch fingers. Clean the brake shoes with Contact Cleaner, hexane, or stoddard solvent. Lightly sand any high, or glazed spots.

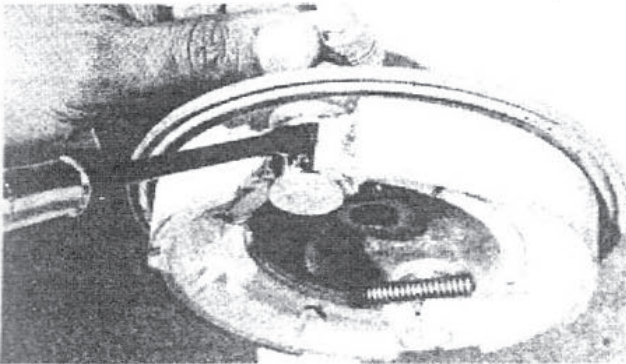

5. The brakes can now be reassembled. After reassembly, lightly grease the brake cam, taking care not to get grease on the brake shoes. Lightly spray the brake springs with Bel-Ray 6 in 1, or WD40, to prevent rust. Also spray the brake pivot lightly. **CAUTION! DO NOT SWITCH SIDES (POSITION) OF THE BRAKE SHOES. KEEP THE RIGHT SHOE ON THE RIGHT SIDE AND THE LEFT ON THE LEFT SIDE. YOU CAN MARK THEM CLEARLY WITH A FELT-TIPPED PEN. EACH SHOE DEVELOPS WEAR CHARACTERISTICS AND CHANGING SIDES WILL ALTER THE WEAR PATTERN.**

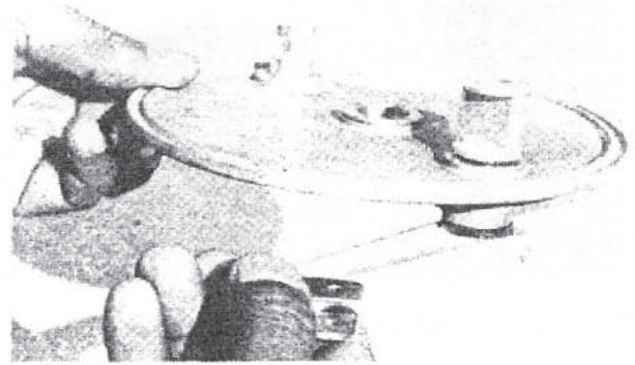

4. Check the brake arm pivot for smooth, easy operation. Lube as needed. If the pivoting action is stiff, disassemble the pivot, clean and grease it lightly. Reassemble. Clean the brake drums and the inner surfaces of the wheel bearings.

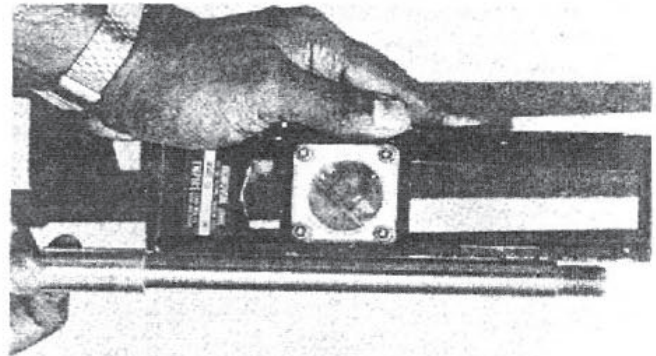

6. Before reinstalling the front wheel, clean and lightly grease the front axle. Wheel bearing grease, or Bel-Ray Anti-Seize, works well for this. If the axle is lightly pitted, or has a trace of rust, it can be sanded with 400 grit emery paper. If it's heavily pitted or has deep corrosion or rust, then replace the axle. Also, check the axle for straightness by laying it on a true surface, such as a pane of glass. If the axle is bent, replace it. Do not straighten and re-use.

**FRONT WHEEL BEARING SERVICE:
REMOVAL AND INSTALLATION**

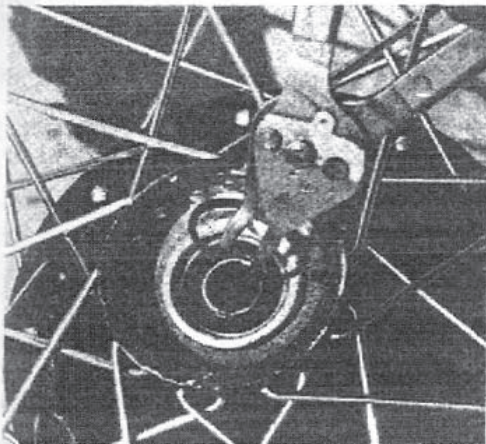

1. Remove circlip securing bearing in place.



2. Heat hub around bearing surface.

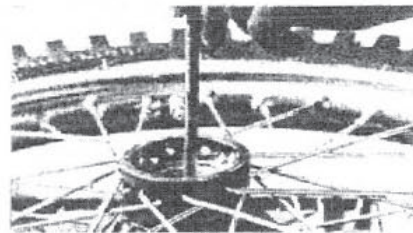

3. Tap out from opposite side with long punch.

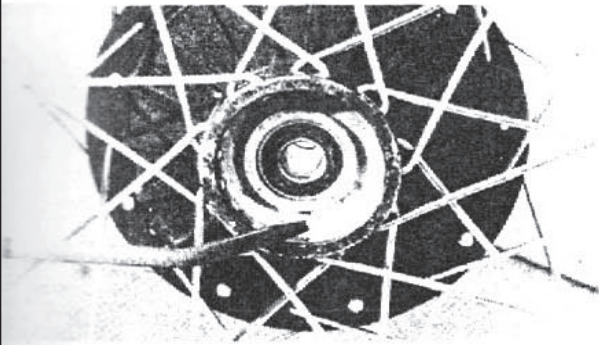

4. Next, heat the other side around the bearing.

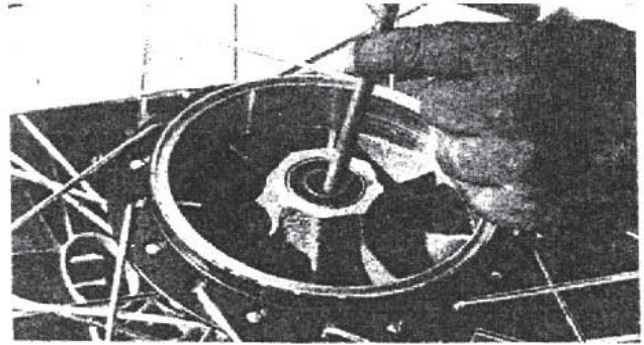

5. Tap out the bearing from the opposite side.

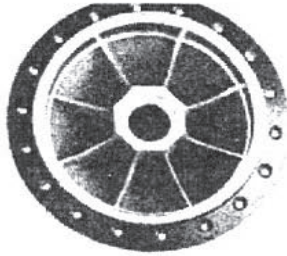

6. A spacer is situated between the two bearings. Here's the proper order of assembly.

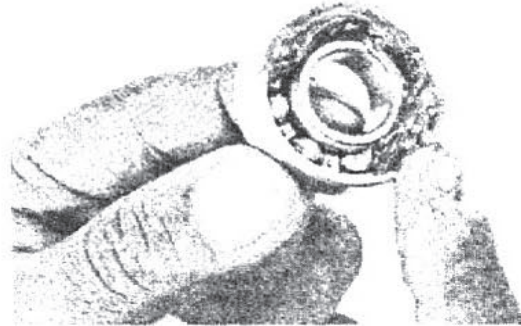

7. New bearings should be greased well with a quality wheel bearing grease, such as Bel-Ray.

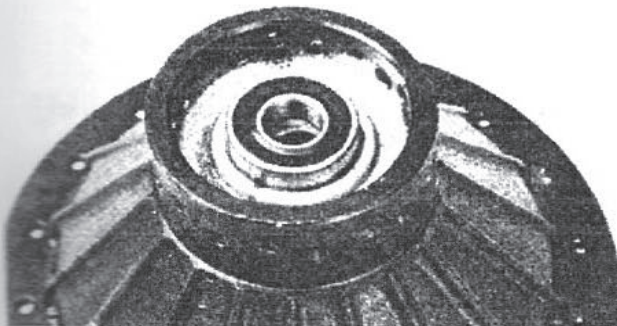

8. In order to install new bearings, the hub should be heated, then the bearing placed over the seat.



9. The bearing can then be tapped home until fully seated.

FRONT WHEEL ASSEMBLY/BRAKE CENTERING

1. Insert the backing plate into the wheel hub.
2. Hold the wheel in place between the fork legs and slide the axle into place. Light tapping may be required.
3. If the axle has to be forced, removed the wheel and find out what the obstruction is.
4. Lightly tighten the axle.
5. Reinstall the front brake cable, using a fresh cotter pin in the lower brake arm.
6. Attach the brake stay arm and lightly tighten down the holding unit.

7. Spin the front wheel in the normal direction, then squeeze down hard on the front brake control level. It's best to have a friend help you do this.
8. While the front brake is being held firmly in place, tighten down the backing plate stay nut and the axle.
9. Release the front brake and adjust the cable to the desired brake tension. Pump forks up and down. Re-hold brake and tighten 10mm pinch bolts.
10. The reason for this is to properly center the brake shoes in the drum and to ensure alignment and maximum area contact, as well as proper axle alignment. This can mean the difference between "mushy" brakes and powerful brakes.
11. Each time the motorcycle is washed, or raced in muddy or wet conditions, the front wheel should be removed and the cleaning and adjusting ritual repeated.

Rear Wheel Disassembly

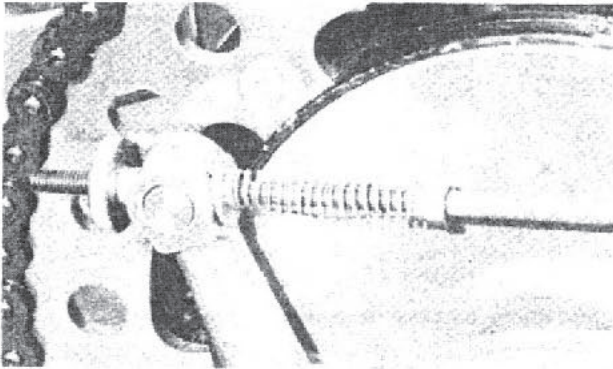

1. Place the motorcycle on a work stand, or sturdy crate, so that the rear wheel is off the ground. Remove the knurled nut on the end of the brake rod. Slip off the cylindrical barrel on the rod, then depress the rear brake pedal. This will pull the brake rod out of the rear brake actuation arm. Remove the spring on the brake rod.

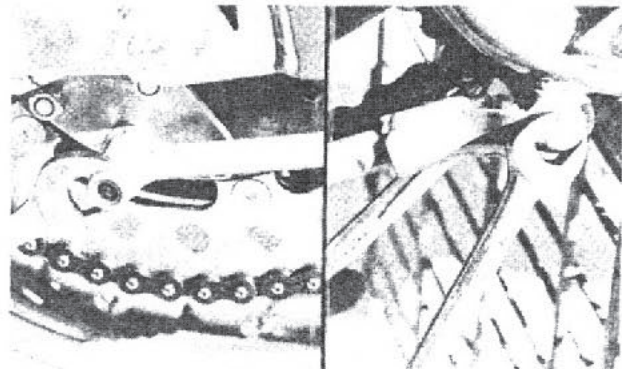

2. Remove the nuts and bolts holding the floating brake stay arm and pull the arm free.



3. Remove the master link from the chain and take the chain off the sprockets. Set it aside. You can also remove the chain from the rear sprocket without taking off the master link by merely slipping the wheel forward and working the chain off the rear sprocket. We recommend that the chain be removed and inspected for wear or damage at this point. It only takes a moment longer. Then, loosen and remove the 24mm axle nut.

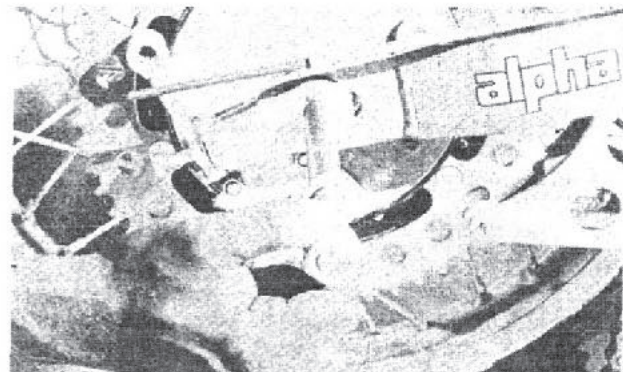

4. Pull the axle out. Light tapping with a rubber mallet may be required. If the axle comes out stubbornly, it may be a sign that the axle is bent, or corroded. Remove rear wheel.

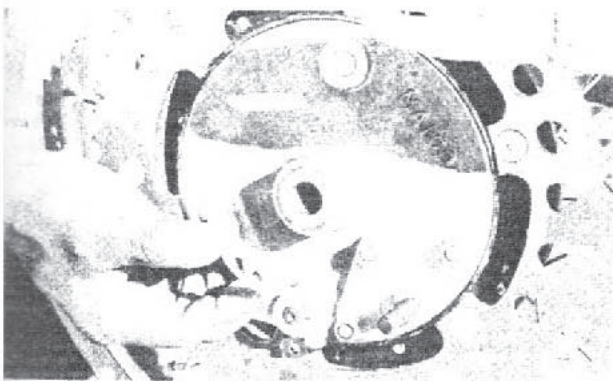

5. Remove the backing plate from the rear wheel. Don't lose the dust cap.

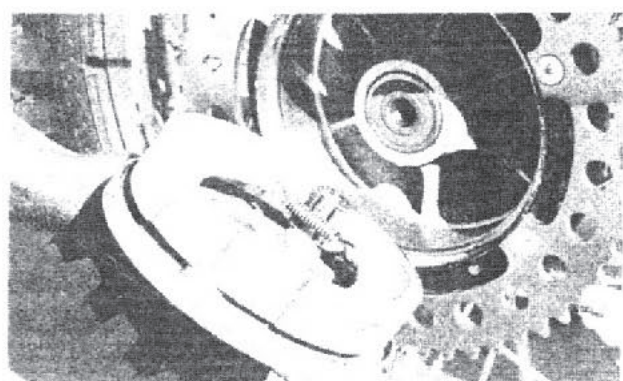

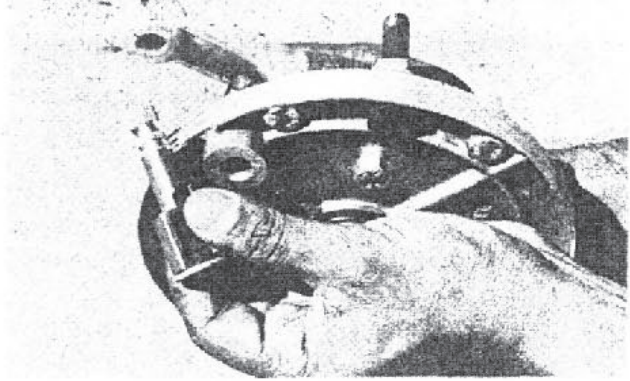
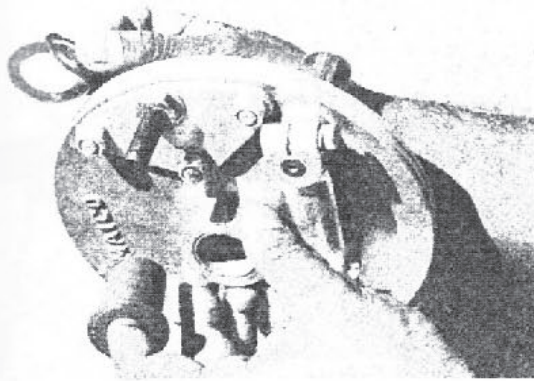

6. Remove circlip holding backing plate bushing. Clean and grease it. Also, remove the cam and service it. It must rotate smoothly.

INSPECTION AND SERVICE

1. Clean the drum, backing plate, brake shoes and all surfaces with a good solvent. The final cleaning on the brake shoes should be with Contact Cleaner, hexane or stoddard solvent. This effectively degreases the brake shoes.
2. Check the brake drum for rust, dirt or glazing. Sand lightly to get rid of any rust or corrosion buildup. If the drum is scored, it should be turned down and refaced.
3. Examine the brake lining. If it's worn, cracked or chunking, it should be replaced. If there are glazed high spots, they can be lightly sanded.
4. Remove the shoes from the backing plate by prying them up at the outer edges. Take off the springs and check for rust or wear.
5. Rotate the brake cam to ensure free movement. If there is some bind, take the nut off the brake lever and disassemble the cam pivot. Clean and grease as needed. Reinstall and check for smooth action. This is especially important after muddy or wet races.
6. Clean the wheel bearings and inspect for excess play and proper sealing. The axle can be inserted into the hub to check for this.
7. The backing plate can now be reassembled in reverse order.

CAUTION! AS WITH THE FRONT BRAKES, DO NOT CHANGE THE POSITION OF THE BRAKE SHOES. KEEP THE RIGHT SHOE ON THE RIGHT SIDE AND THE LEFT ON THE LEFT SIDE. SHOES CAN BE MARKED WITH A FELT PEN TO MAINTAIN THE PROPER WEAR PATTERN.

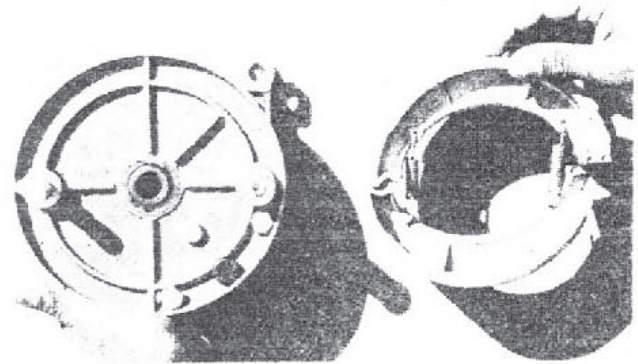

ASSEMBLING THE REAR WHEEL

1. Place the assembled backing plate into the hub.
2. Insert the rear wheel (with the backing plate) into the swingarm. Insert the axle in the right side, through the axle adjuster and into the backing plate. As the axle starts into the backing plate, the spacer on the left side should be slipped into place. Make sure that the brake rod is near the rear brake arm. Tap the axle lightly home, taking care that it engages the spacer and the left side axle adjuster. Do not damage the axle threads as the axle is tapped through.
3. Tighten the axle nut down lightly and spin the wheel to see if it rotates freely.
4. Install the chain on the rear sprocket, making sure that the master link is in good shape. If there's any appreciable wear on the ends of the link pins, use a fresh master link assembly.
5. Hook up the brake stay arm and tighten lightly.
6. Slip the brake rod through the brake arm, with the spring in place, forward of the arm. Put on the barrel and the round nut and roughly adjust the rear brake.
7. Check the chain tension. Proper adjustment is indicated in the photo. Press up on the chain; the chain should not go higher.
8. Spin the rear wheel in the normal forward direction and have someone step on the brake pedal and hold it down. Then, tighten down the backing plate nut and the axle nut. The pedal can now be released. This helps to center the brake shoes, providing maximum braking force.
9. Adjust the rear brakes to the desired feel. The brake pedal can also be adjusted to the desired height. Experiment.

WHEEL BEARING REMOVAL AND INSTALLATION

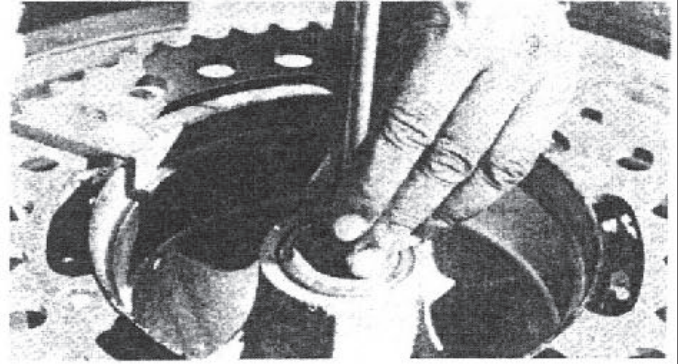
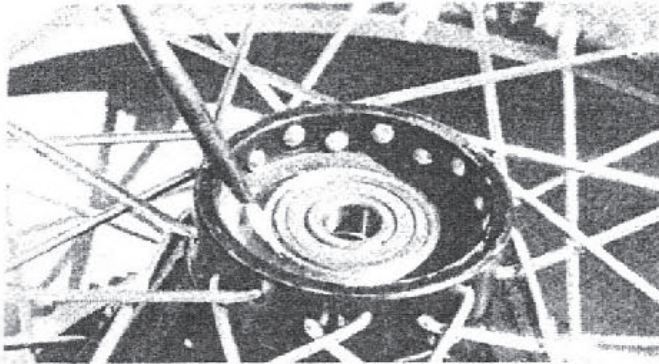

1. The hub should be heated around the bearing with a torch. Keep the tip moving and take care not to damage the aluminum.

2. Using a long punch, the bearing can then be tapped out from the opposite side.

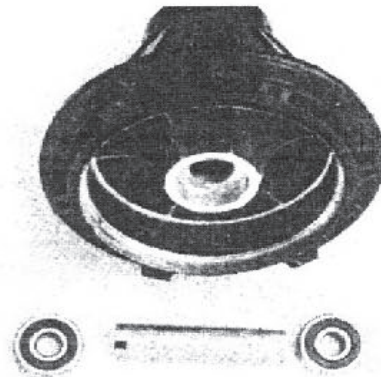
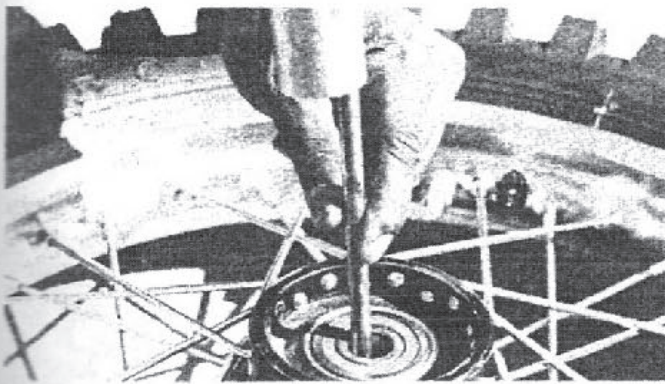

3. Now heat the opposite side bearing housing with the torch. Turn the hub over and tap the remaining bearing out.

4. You'll find a spacer inside the hub. To install new bearings, heat the housings and lightly tap them home, using a block of wood, or a soft mallet.

CHAIN ADJUSTMENT

The Maico has a very simple, yet positive, chain adjusting system. A 13mm adjusting nut rides against a tab on the rear of the swingarm. Another 13mm jam nut holds it securely in place. By

twisting the forward nut clockwise, the axle will be pushed back, tightening the chain. Reverse the process to loosen the chain. Assure that both sides are even to keep the rear wheel straight.

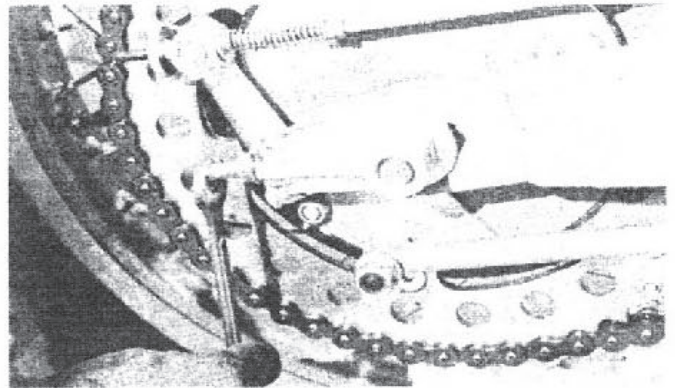
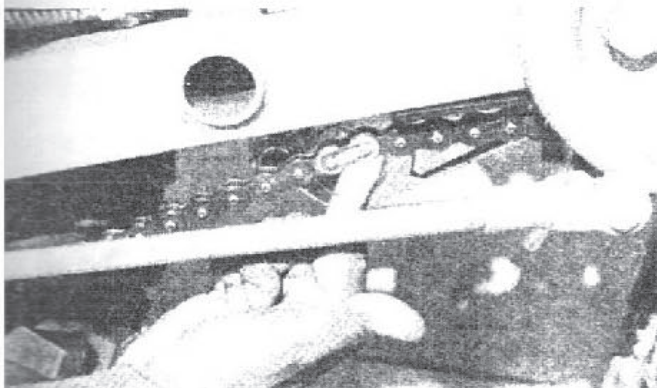

A. Proper chain tension should be checked at this point.

B. The rear axle can be moved forward or back for desired tension by turning the adjusting nut. After adjustment, the jam nut should be tightened, and the rear brake adjustment rechecked.

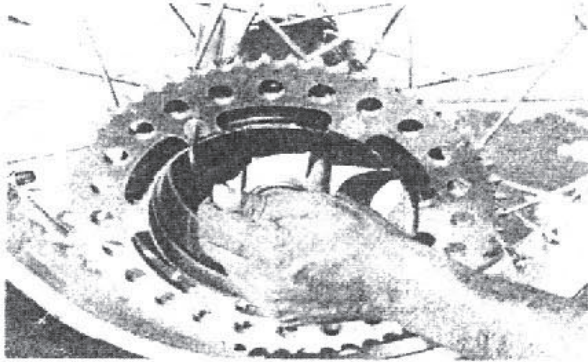

C. Always check the sprocket bolts on a regular basis. An allen wrench is used on the outer side.

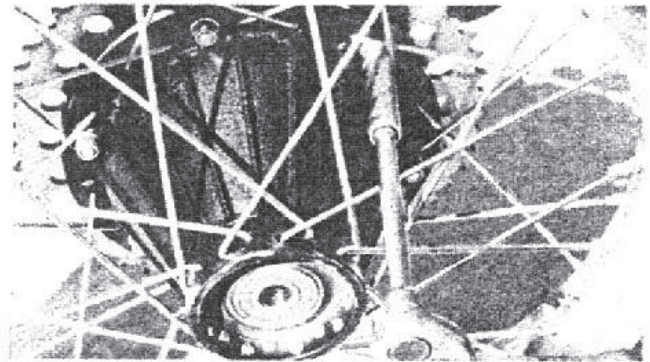

D. You'll need a socket and an extension to properly tighten the lock nuts. Always tighten the nuts *after* the allen wrench is used.

Shock Removal

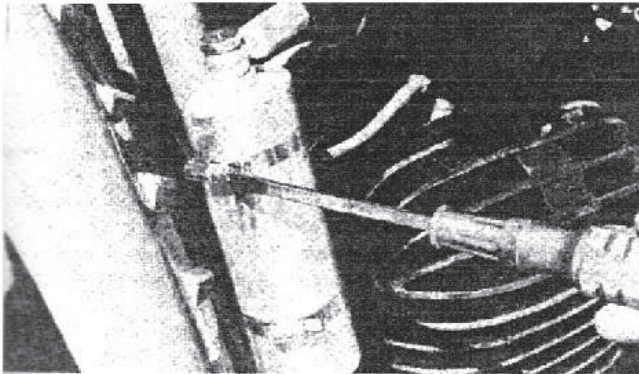

1. Remove clamps from reservoir and then remove tank from chassis.

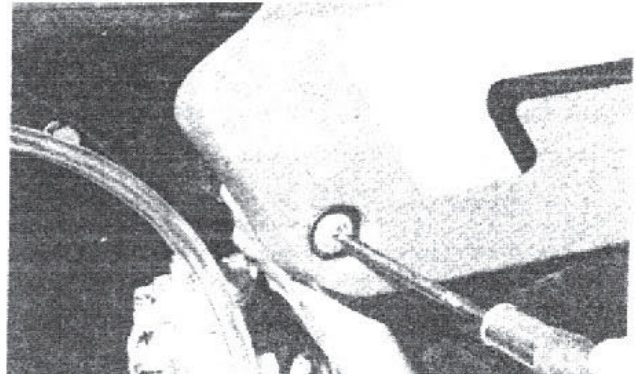

2. Remove side panels and saddle.

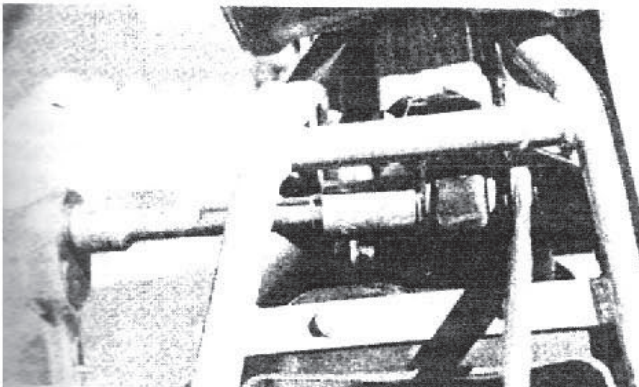

3. Loosen and remove nut on top shock bolt. Do not remove bolt at this point.

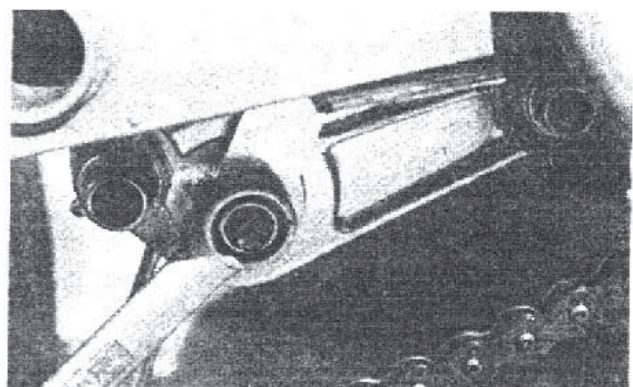

4. Loosen and remove center bottom shock nut and bolt (19mm).

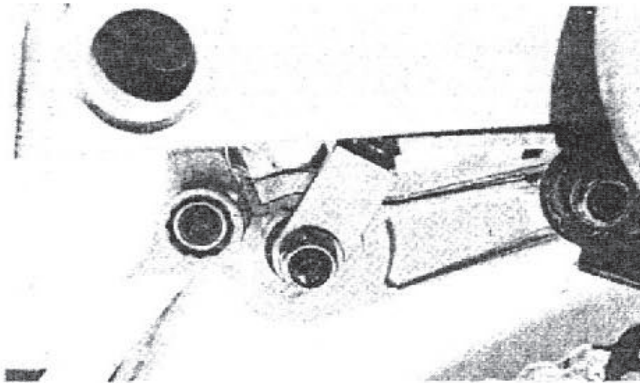

5. Remove rear link bolt (19mm).

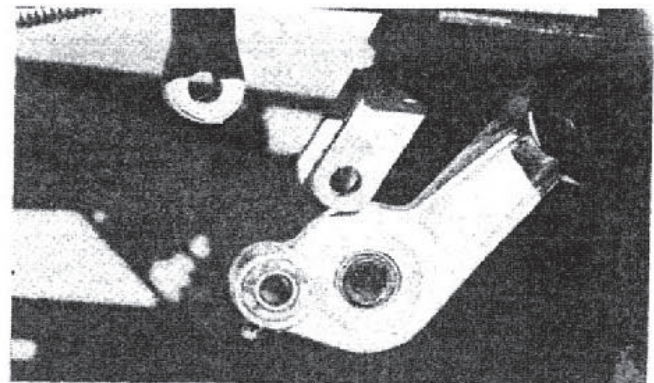

6. Bottom of shock is now free.

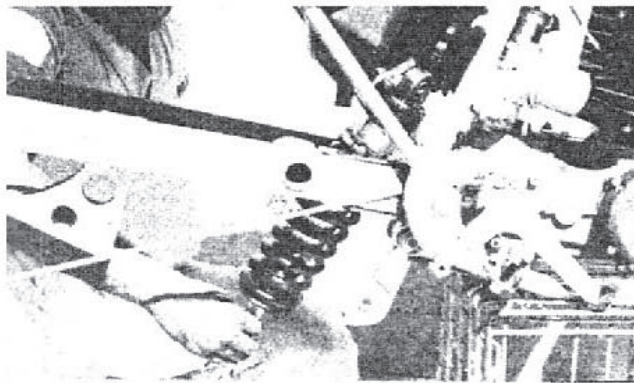

7. Now remove the top shock bolt and lower the shock down and out. The swingarm will have to be raised up a bit for clearance.



8. Follow through with the hose and the reservoir. The swingarm may have to be jiggled as the top of the shock is worked through. The shock can now be removed and serviced as needed.

Shock Rebuild

CORTE & COSSO SINGLE-SHOCK: TYPE AND FUNCTION

The Maico is equipped with a Corte & Cosso shock with a remote, gas pressurized reservoir. The shock features adjustable external rebound damping (60 positions total) and has adjustable spring preload by turning a threaded ring.

The compression damping can be altered, but disassembly is required for this. Additionally, there are a number of washer sets available to vary both the compression and the rebound damping characteristics. It is recommended, however, that the racer utilize the 12 damping "washer" stack that comes stock with the 1982 Maico. Tests have shown that most riders prefer this combination.

Technical Information

Shock length	47mm
Spring diameter	14mm stock
Spring weight	12.4 kp stock
	12.3 kp optional
	12.5 kp optional
Standard spring length	255mm
Setting preload of the spring length	17mm
Spring service limit	235mm

NOTE: Spring weight is after the spring is compressed 1mm

RECOMMENDED OIL FOR CORTE & COSSO MAICO SINGLE-SHOCK

This higher viscosity index Bel-Ray oil is made from a petroleum hydrocarbon fortified with a methacrylate Type VI improver that is shear resistant. It is through the use of the VI improver that this high viscosity index is achieved.

High viscosity index is desirable for shock absorber applications, because it maintains a uniform viscosity over a broad operating range.

If the shock absorber is heavily stressed, oils with polymers are not desirable. It's more desirable to have a shock absorber oil with high viscosity index that does not lose viscosity due to the shearing of VI improver.

Use of any other than Maico shock oil could change the damping character substantially and show significant variation in the rebound and compression systems.

Maico shock oil is available through the Maico distributors. Part order No. 82207

Technical Information

Viscosity index	123.4 SSU at 100°F
	51 SSU at 210°F
Viscosity index of 300 and Pour Point of -80°F	

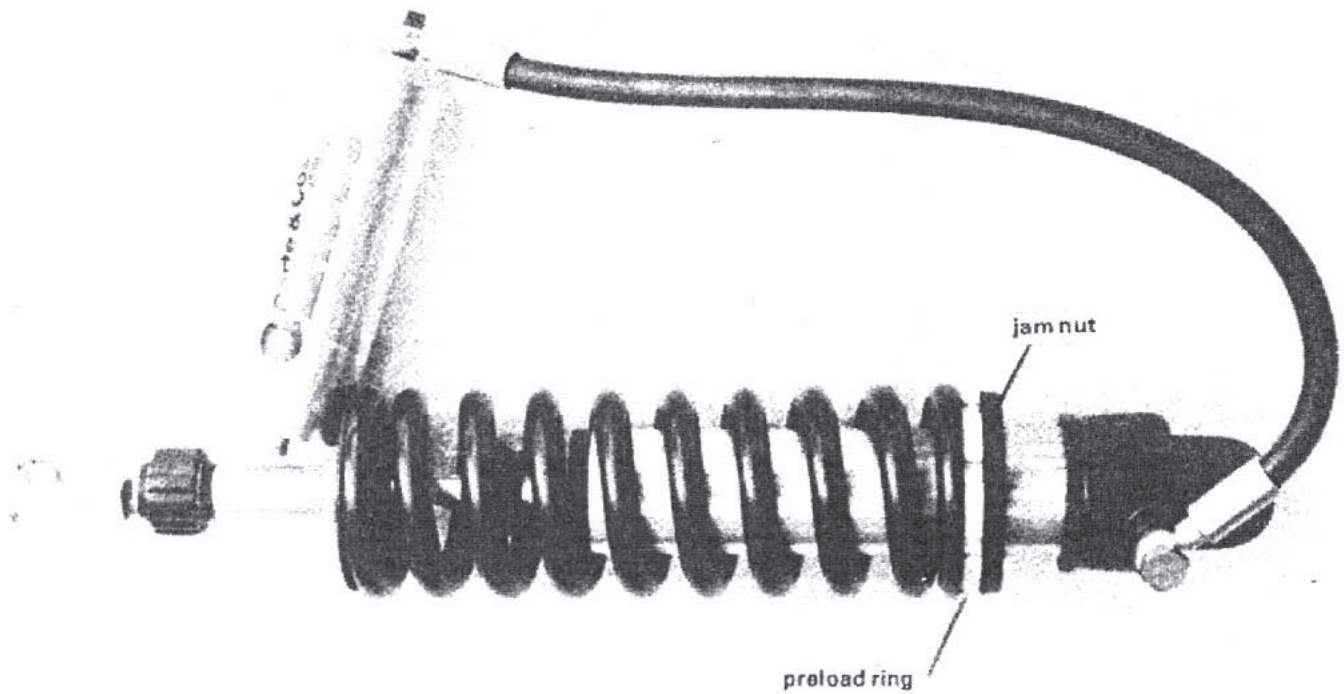

1. Clean the shock thoroughly before working on it and work in a clean, dust-free area. Place the top of the shock firmly in a vise (upside-down) and release all of the preload by loosening the jam nut and the preload ring.

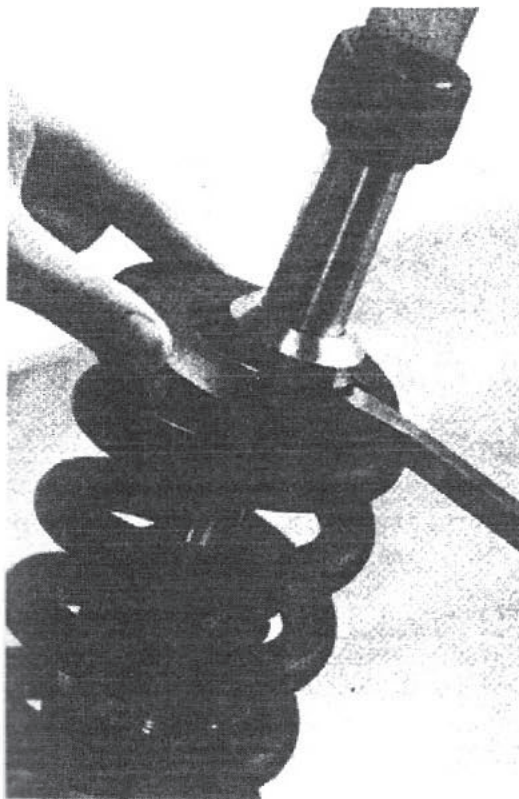

2. With the spring loose, the retaining clip can be pried off while the spring is pressed down with the aid of a large, flat screwdriver. Remove the spring.

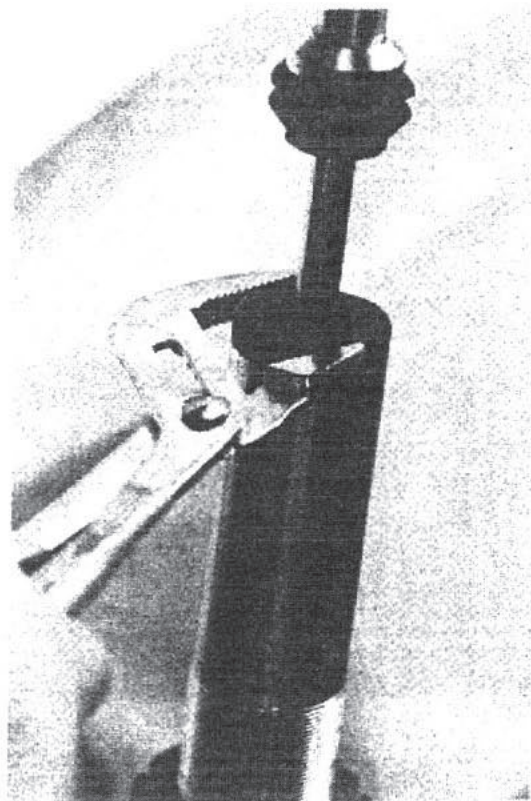

3. Unscrew the body cap. This can be done with a typical steering head adjusting tool.

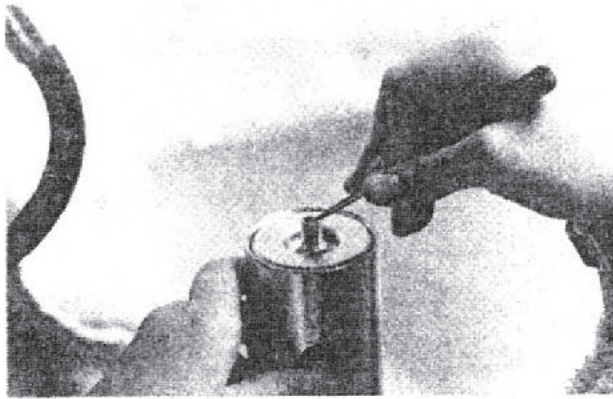

4. Remove the valve cap and depressurize the reservoir. Make sure all of the gas is out before proceeding.

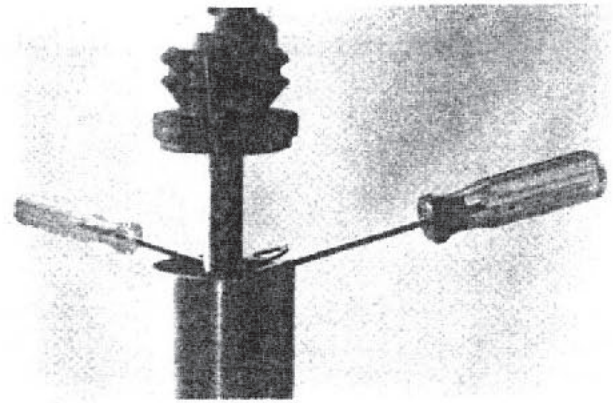

5. With the shaft fully extended, push down on the shaft bearing until the circlip is clear. Then, remove the circlip with two slender flat-tipped screwdrivers.

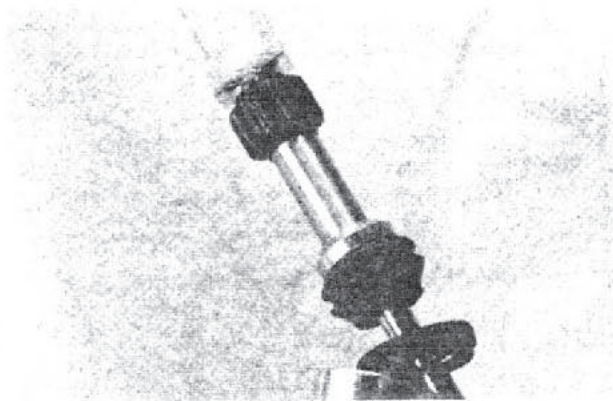

6. Set all parts aside in a handy container, with the body in an upright position to retain the oil. If you are merely changing the oil, steps 8, 9 and 10 can be eliminated. However, if you are changing or servicing the valving, proceed on.



7. Clamp the shaft in a suitable set of bronze, aluminum or lead jaws, in a vise. This will prevent damage to the plated shaft surface. Loosen the locknut and remove.

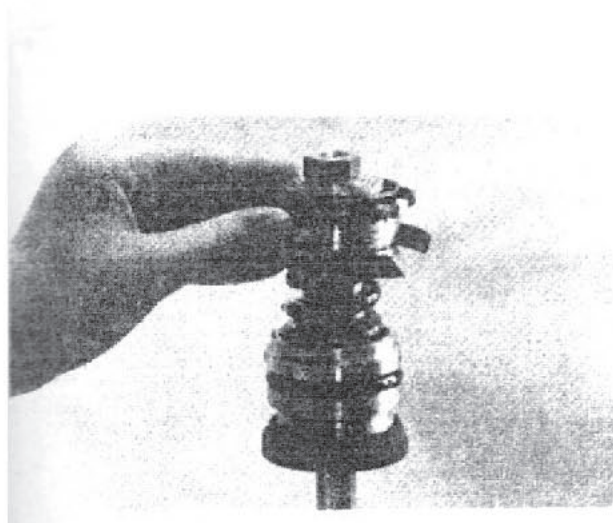

8. The entire valve assembly can now be removed in this order: rebound valves, piston, compression valves and piston bushing.

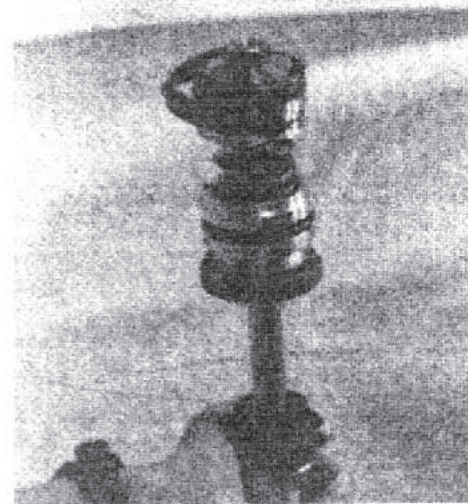

9. Damping valve assembly

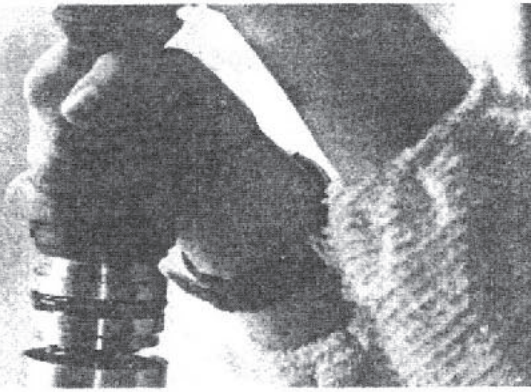

10. Check all parts for wear and replace as needed. If valving changes are to be made, assure that the correct stacking order is maintained. Place Teflon strip bushes on piston and bushing seats and install the shaft assembly very slowly and smoothly back in the body. Make sure they stay seated in their grooves as the assembly is inserted. Naturally, all parts must be scrupulously cleaned before reassembly. Even a small speck of dirt can harm the damping characteristics, and perhaps damage the shock.

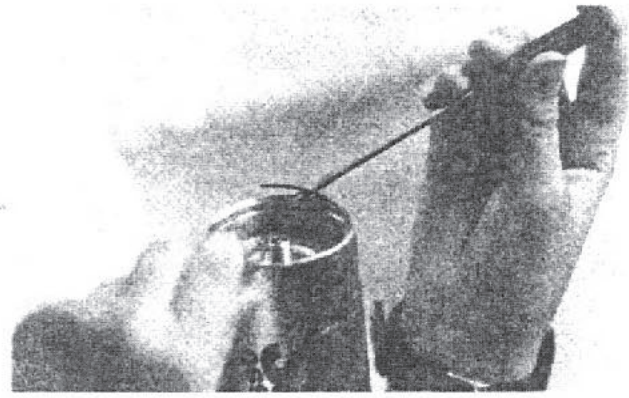

11. If oil is to be changed, the body and reservoir must be drained and thoroughly cleaned. To do this, the reservoir must be taken apart. This is easily accomplished by pushing down on the reservoir cap and removing the retaining ring with a slender screwdriver. The cap can then be pulled off. To remove the floating piston inside the reservoir, the banjo fitting on the bottom of the reservoir must be removed and the piston pushed out with a wire rod. The banjo fitting can then be reinstalled.

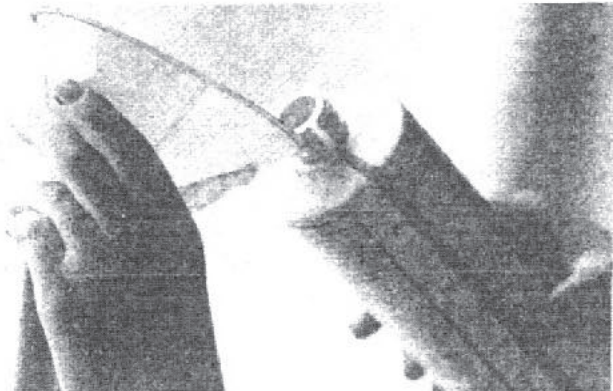

12. The shock can now be refilled with oil. This is best accomplished by putting the reservoir firmly in a vise *WITH* the shock body, keeping both of them in an upright position. Oil can then be slowly poured into the body and the rod and assembly gently worked up and down until no more bubbles can be seen.

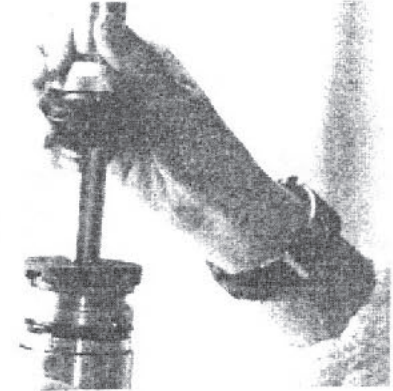

13. Insert the shaft bearing and push it down very slowly until the circlip can be inserted. Oil will spill over during this step, so have a drain pan under the working area. Work the shaft up and down and recheck the oil in the reservoir. Pull the shaft to the fully extended position.

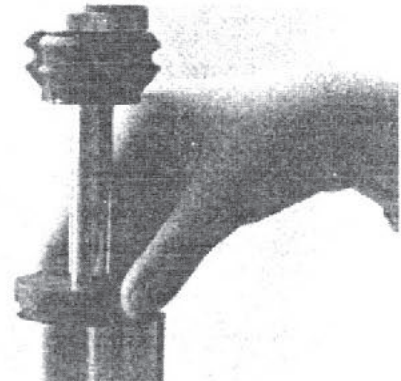

14. Screw the body cap on by *hand pressure only*. Use Loctite on the threads.

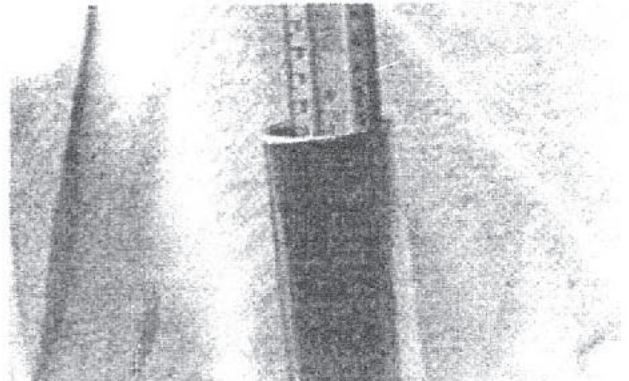

15. Check to make sure that the piston is exactly 90 mm in the reservoir. Reinstall the cap and the retaining ring and pressurize the reservoir to 12 to 15 atm (psi). After pressurization, the body cap can be tightened with a tool to about 1.5 Kgm. The gas pressure will keep the shaft bearing from turning. Complete reassembly.

Special Tools

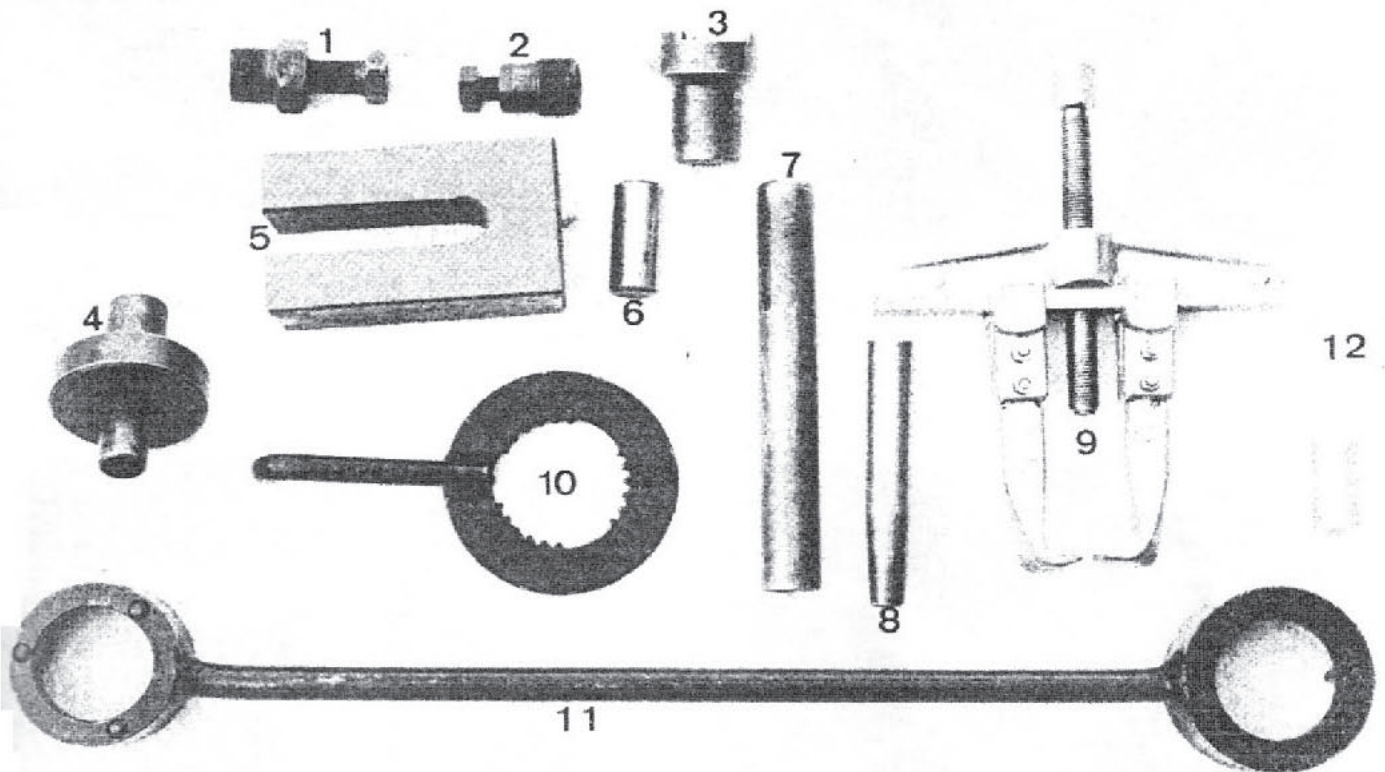

SPECIAL MAICOTOOLS

1. — Bosch flywheel puller. 2. — Motoplat flywheel puller. 3. — Clutch lock tab tool. 4. — Oil seal and bearing insert tool. 5. — Connecting rod holding tool (use with No. 6). 6. — Rod pin insert. 7. and 8. — Transmission snap ring inserting tools. 9. — Clutch puller. 10. — Clutch body holder. 11. — Crank sprocket holder. 12. — Piston pin extractor.

Engine Removal

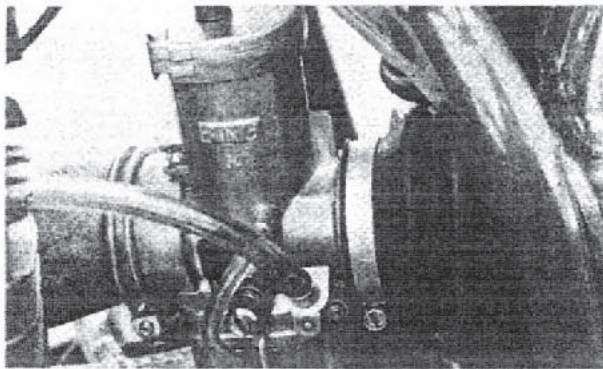

Before starting removal, clean the engine and the chassis thoroughly. **NEVER** work on a dirty machine.

1. Remove the saddle. Two 13mm bolts hold the seat in place. Make sure the petcock is turned off, then remove the fuel line from the carburetor.

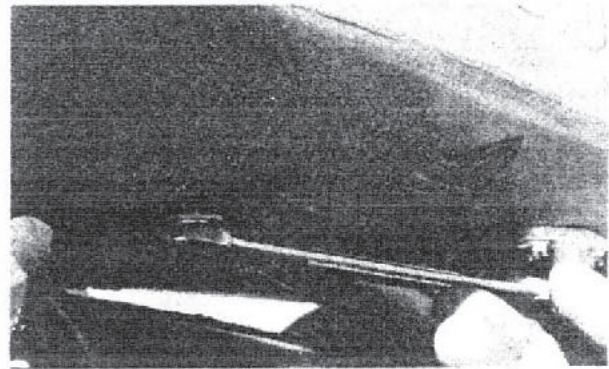

2. Loosen the tank strap, then remove tank by rocking it to the rear, then upward. The side panels can be removed at this point. Phillips screws hold the panels in place. As long as you are removing the engine, the side panels allow a more complete inspection of the machine.

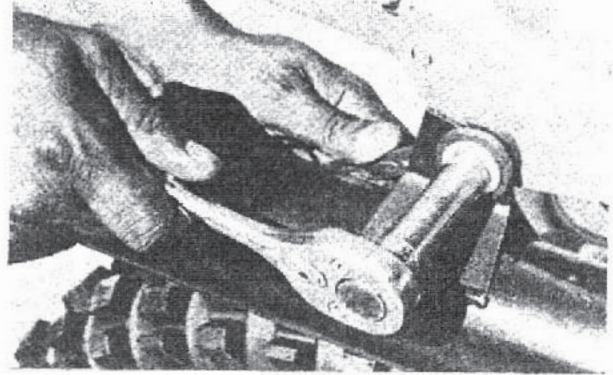
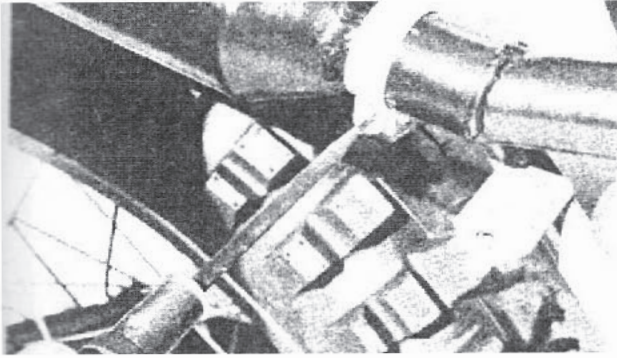

3. Remove the clamp and the mounting bolt for the silencer. Take off silencer. Take the clip off the master link, remove the link itself and remove the chain.

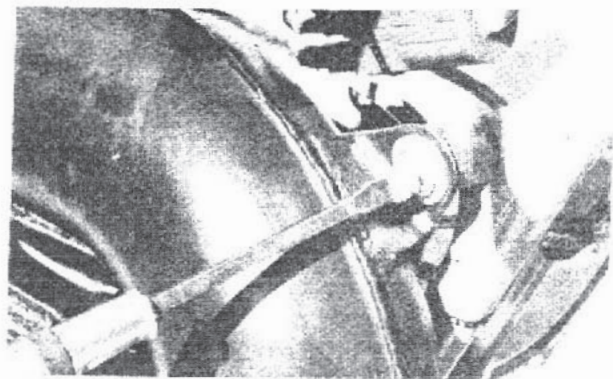
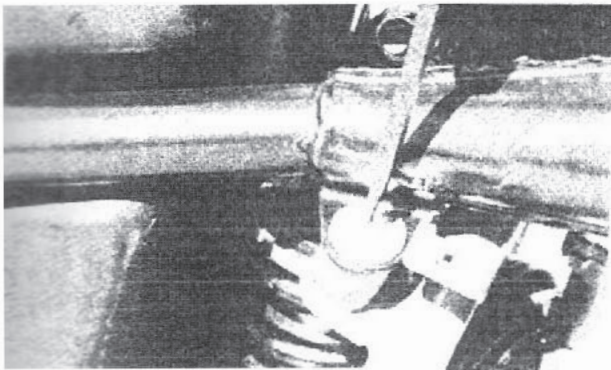

4. Loosen and remove all the bolts on the exhaust system.

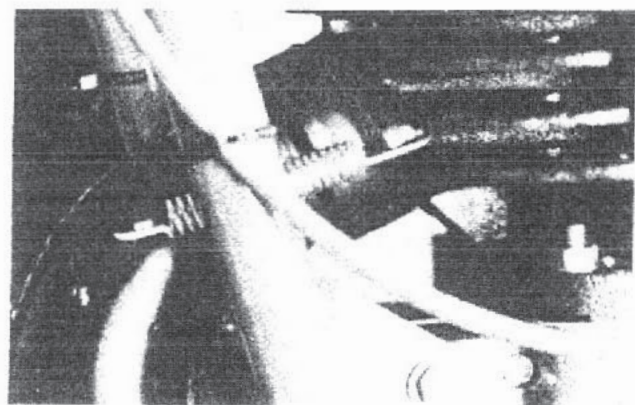

5. Remove the head pipe springs, or attaching bolts, and remove the exhaust pipe. This can be accomplished

easier by rotating the pipe and cocking the front wheel to one side as the pipe is being slid out.

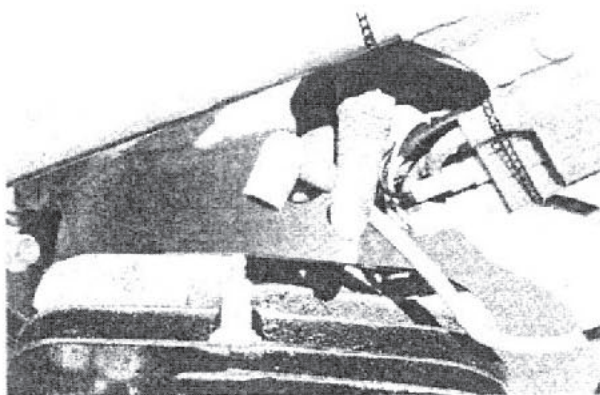

6. Remove the spark plug cap from the spark plug. Tuck the spark plug lead in front of the downtubes to keep it out of

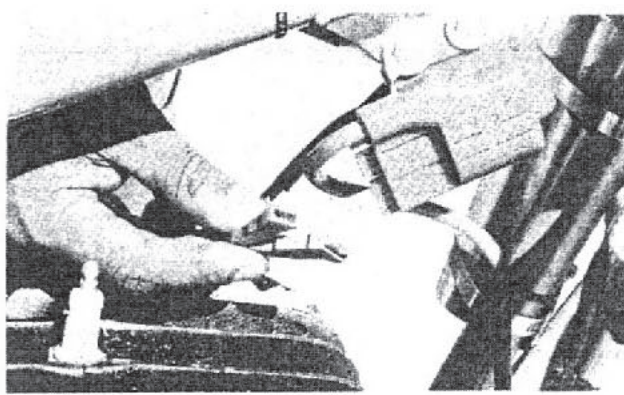

the way. Remove kill button. Disconnect compression release (490 only). Detach wiring from coil.



7. Remove the clutch cable. This is done easily by using a large flat-tipped screwdriver to push the clutch actuation arm forward, then slipping the fitting out of the tip of the actuation arm.



8A.

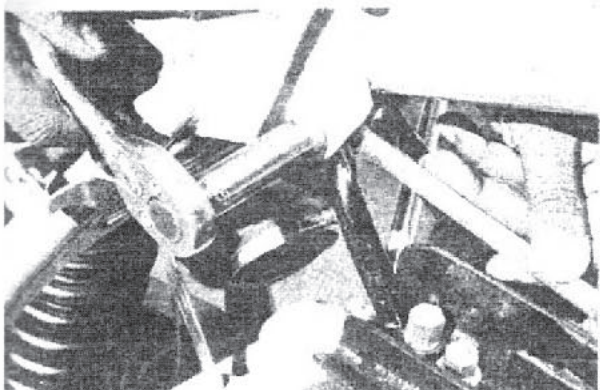

8B.

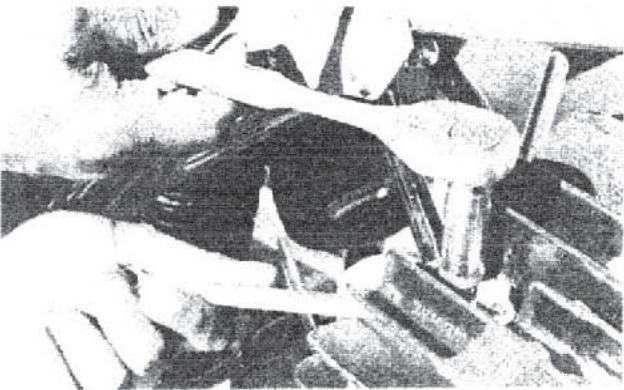

8C.

8 A . B . C . Remove carb and head stay.

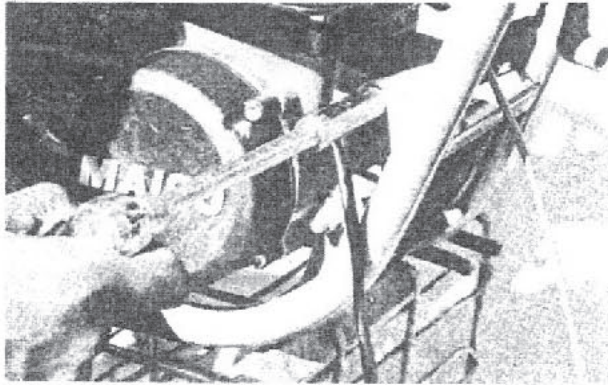

9. Loosen and remove the two front motor mount bolts. Use a 13mm wrench and deep socket for this.

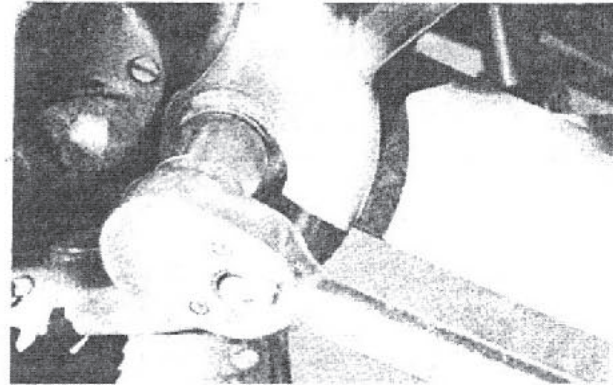

10. Remove the swingarm pivot nut (22mm) and tap the swingarm pivot.

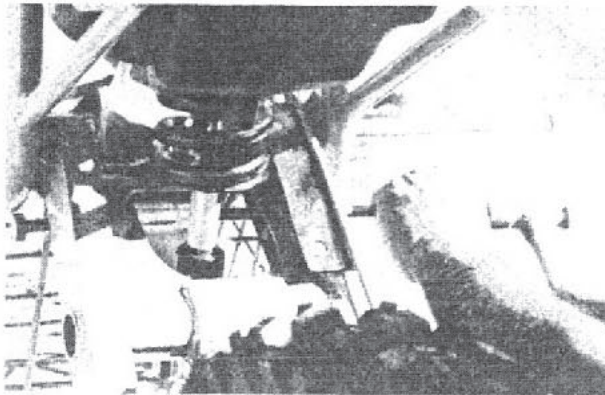

10 A.

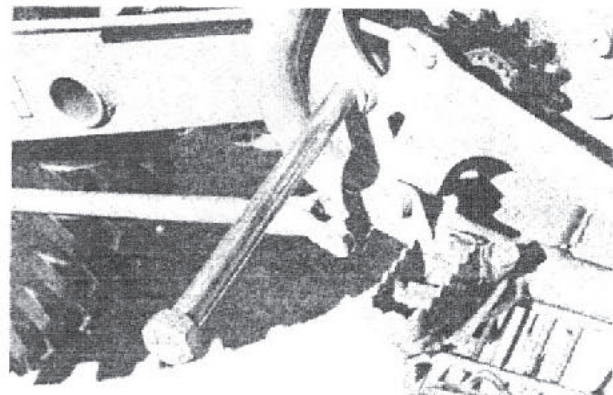

10 B.

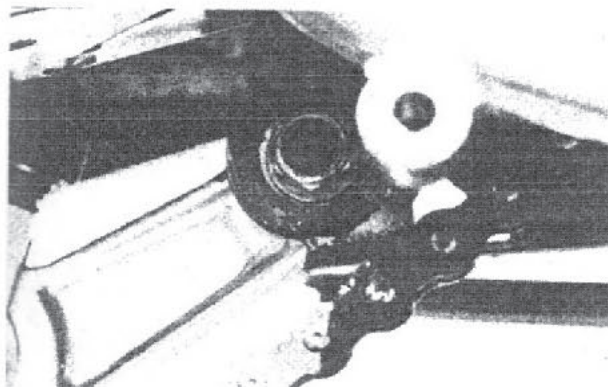

11. Remove bottom front shock link bolt (19mm, 17mm nut) from suspension. Bolt out gently. Use a plastic or lead drift, or tap with a wood piece to prevent thread damage. This will also allow the swingarm to come loose and it should be braced to prevent it from falling loose.



12. The engine can now be removed by rocking it up at the rear, then wiggling the front up. After the mounting points are cleared, the engine can be easily lifted out of the left (shift side) side of the frame. The swingarm may have to be partially raised for clearance.

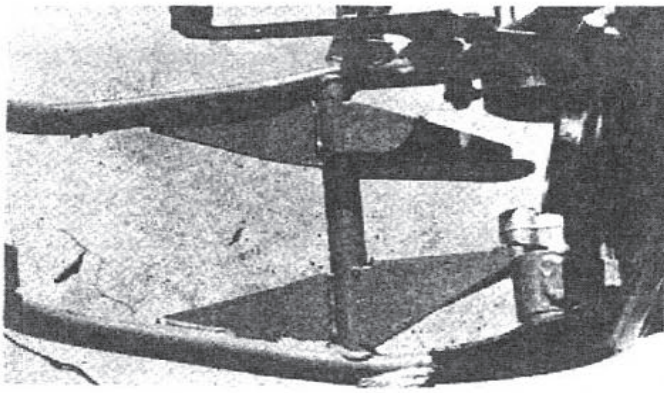

13. At this point, it's advisable to re-clean the frame thoroughly, as certain areas will be exposed completely. Also, it's a good idea to check for cracks, bends and possible stresses on the frame.

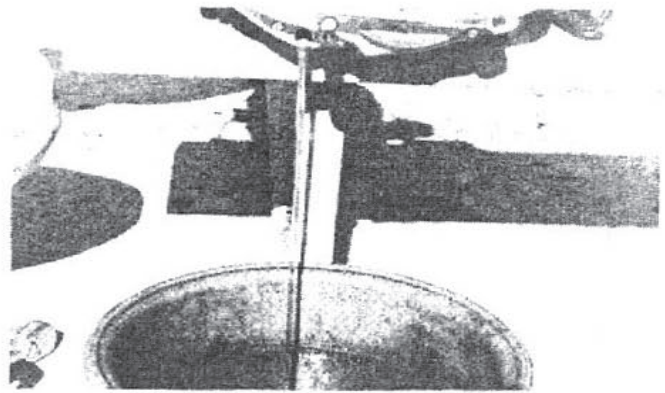

14. Drain oil from the engine.

Engine Teardown, Top End and Mag

ENGINE TEARDOWN



1. Remove kickstarter. A 10mm bolt holds it in place.

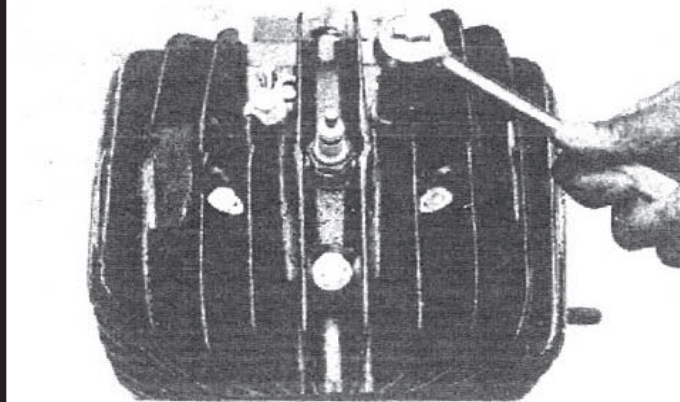
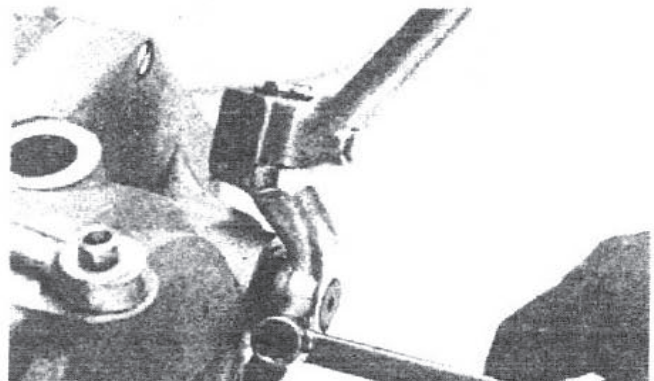

2. Remove cylinder head nuts and washers.

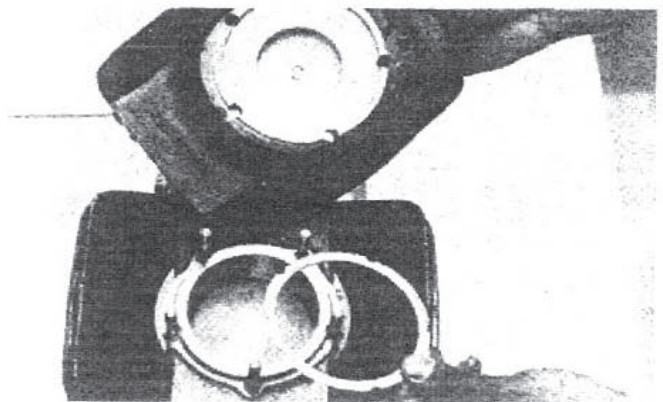

3. Lift off head and head gasket.

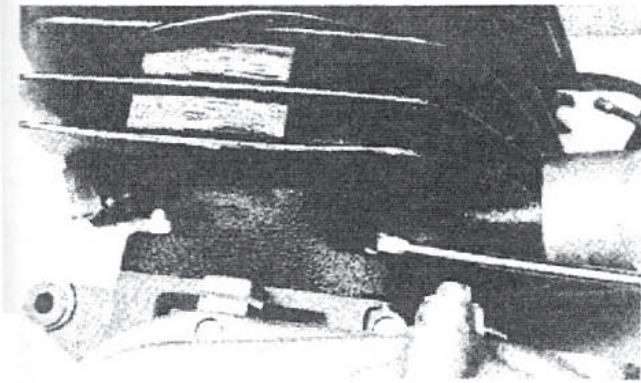

4. Loosen and remove four base nuts (13mm). An open-end wrench must be used.

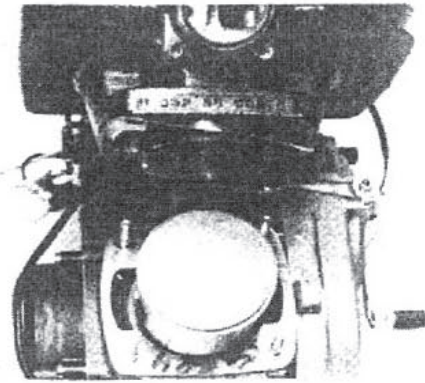

5. Carefully lift off barrel and set aside.

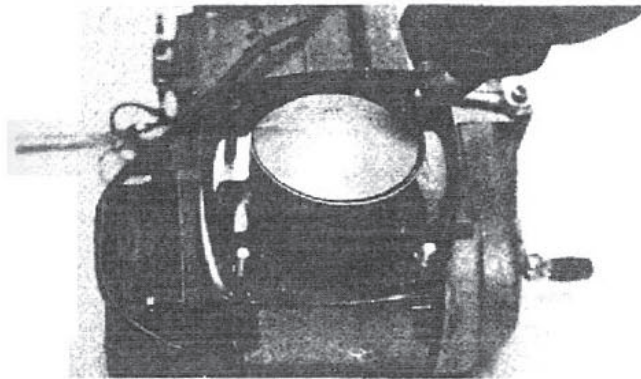

6a. Remove base gasket. Use a razor blade, if necessary.

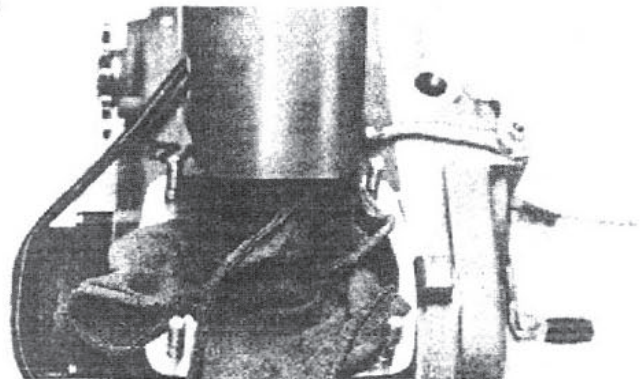

6b. Wrap a clean shop rag (or cloth) around the rod. This will prevent dirt and dust from entering the lower end, as well as protecting the rod from getting nicked on the case edges. Also, it will keep the circlips from falling into the lower end in the event of a tool slipping.

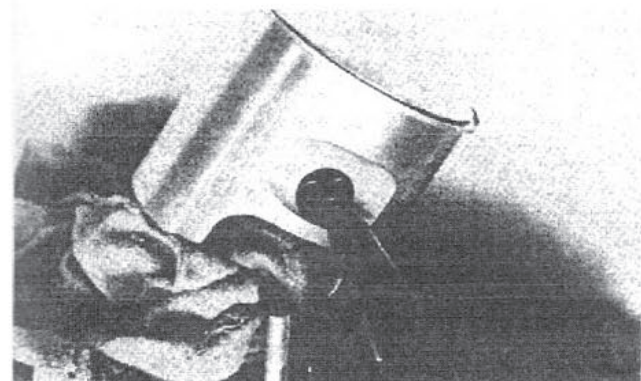

7. Using a pair of needle-nose pliers, remove the circlips from the piston pin edges. Do not re-use them. Always use new circlips. They are cheap and engines are not.

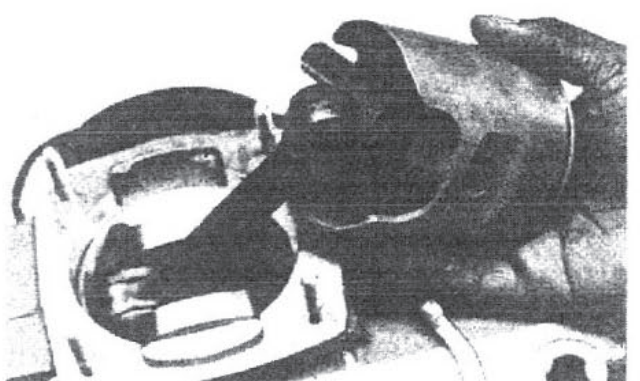

8. Push out the wrist pin. If it's hard to remove, you can lightly tap it out with a blunt tool. If it resists, then use a pin puller. Hitting the pin with hard hammer blows can cause the rod to bend. This is cause for considerable grief. Use your head, not your muscle. Examine the piston, rings, cylinder, pin and bearings for wear.

REMOVING MAG

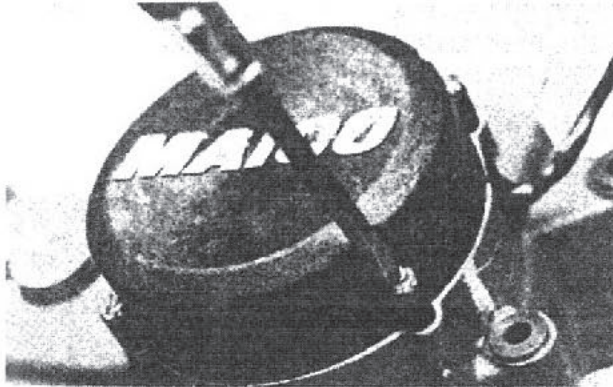

1. Remove the four straight slot screws holding the black ABS cover from the right side of the engine. Lift the cover off.

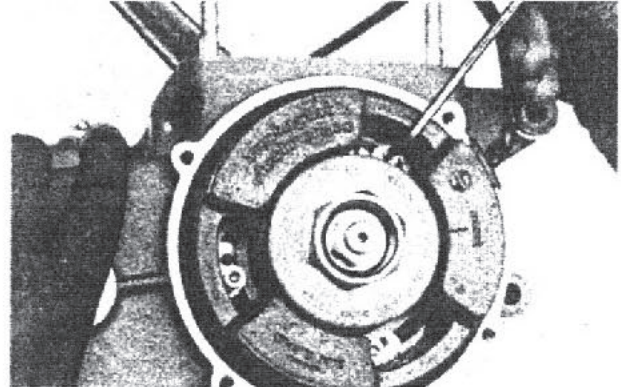

2. Loosen and remove the three allen bolts (4mm) that hold the stator in place.



3. Remove stator. Rubber wire holder in case cover slips out easily.

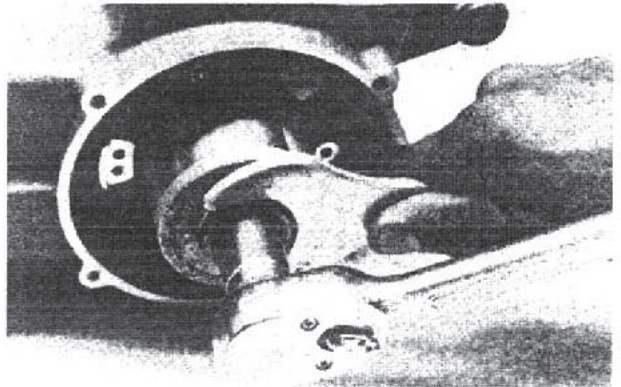

4. Loosen the 17mm nut on the rotor. A 32mm wrench can be used to hold the rotor firmly. NOTE: — THIS IS A LEFT-HAND THREAD.

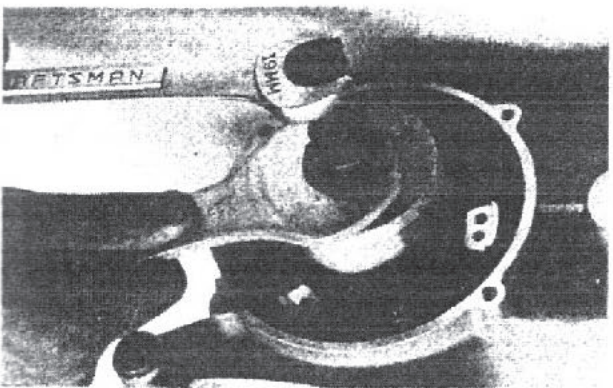

5. Place the special puller (Motoplat or Bosch, depending on the model) in the rotor and extract the rotor slowly. The enduro bikes come with the Bosch, the motocross versions with Motoplat.

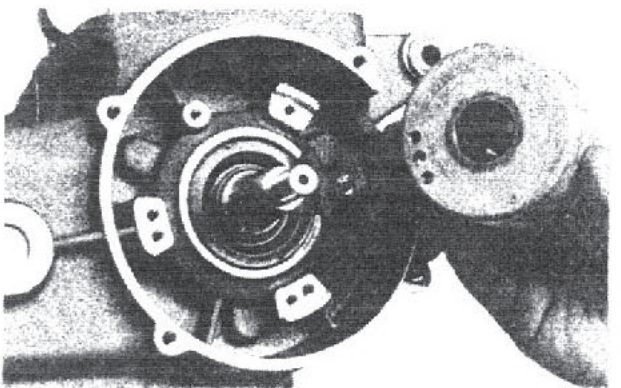

6. Remove the rotor. NOTE: — When the rotor is removed, the system must be re-timed. Please see details on timing in the engine reassembly section.

Reed Assembly

250 ENGINE REED ASSEMBLY

While the 490 Maico engine is a piston port unit, the 250 is a reed controlled set-up. The reed assembly should be regularly checked (every six to eight races) for crack-

ing, warping, heavily discolored or poorly seated reeds. Hard starting with an otherwise sound engine is one sign of deteriorating reeds.

In order to get to the reed assembly, the carb must be removed.



Six allen bolts hold the manifold in place over the reed assembly. Loosen and remove these. The manifold should lift off easily. If not, very light tapping with a rubber mallet is permitted.

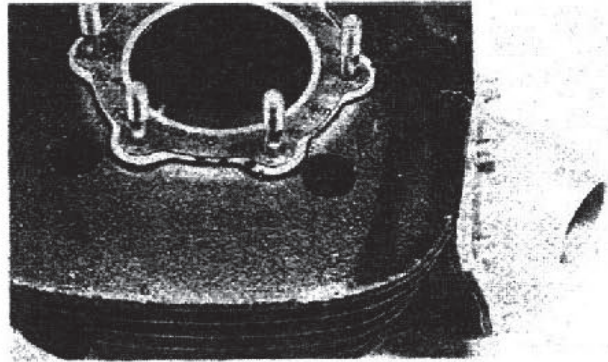

2. Here's a full reed assembly. The reeds must lay flat against the reed block face for best performance.

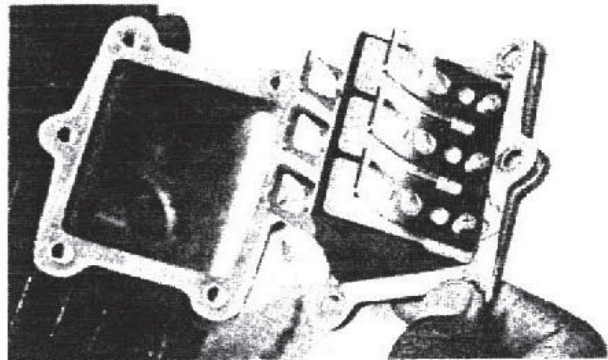
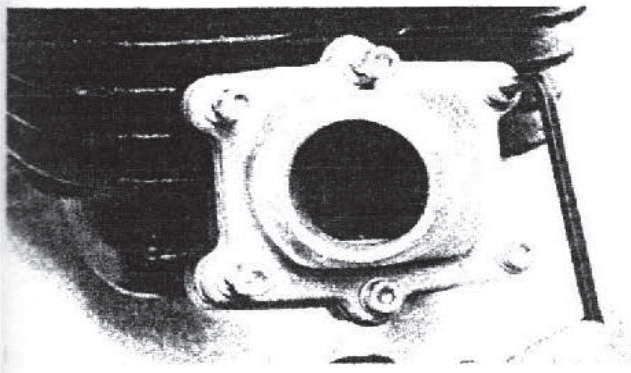

Top End Tolerances

BORE, PISTON AND RING TOLERANCES

Maico offers up to fifth over on pistons and rings. This gives the rider a long and useful service life. The top end should be removed regularly and the wear limits checked.

Ideally, the bore should be checked with an inside dial bore gauge. The ring end gap must be checked with a feeler gauge (10 to 12 thousandths is the proper ring end gap).

Piston clearance should be checked 20mm from the bottom of the skirt with a micrometer. Refer to the enclosed chart for wear items.

NOTE:—For proper honing, use Sunnen Cylinder Hones AN300 grit, with at least 45° to 60° cross-hatch for all Maico cylinders. Do not use flex hones (Ball hones). Deburr the parts slightly with a file or porting tool.

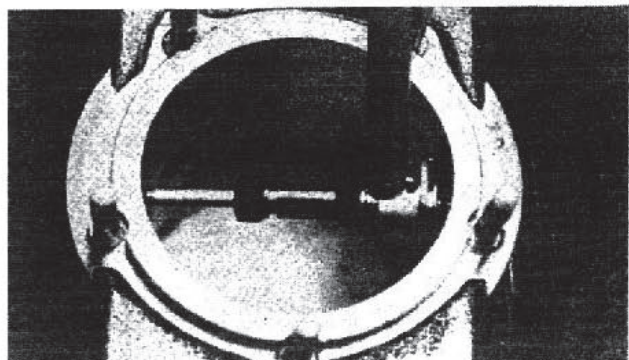

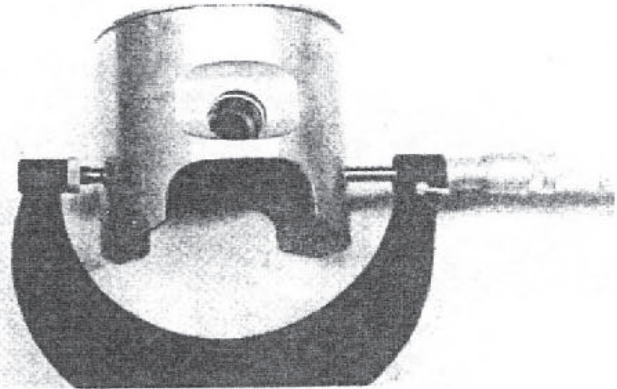

Ring and gap	Stock	Service Limit
250cc	0.3-0.4mm	0.55mm
400cc	0.4mm	0.6mm
490cc	0.4mm	0.6mm

CYLINDER, PISTON, RING CLEARANCE AND SERVICE LIMIT

250cc	Piston Size in mm	Piston Part No.	Ring Part No.	Cylinder Bore Size in mm	Proper Clearance in mm	Service Limit	
						Cylinder Bore Size in mm	Maximum Clearance in mm
Std.	66.96	6918	6919	67.01	0.05 (0.002")	67.08	0.12 (0.005")
First	67.15	6920	6924	67.20	0.05 (0.002")	67.27	0.12 (0.005")
Second	67.35	6921	6925	67.40	0.05 (0.002")	67.47	0.12 (0.005")
Third	67.55	6922	6926	67.60	0.05 (0.002")	67.67	0.12 (0.005")
Fourth	67.75	6923	6927	67.80	0.05 (0.002")	67.87	0.12 (0.005")
Fifth	67.95	6929	6928	68.00	0.05 (0.002")	68.07	0.12 (0.005")
490cc							
Std.	86.42	6813	6814	86.49	0.07 (0.003")	86.54	0.12 (0.005")
First	86.62	6815	6820	86.69	0.07 (0.003")	86.74	0.12 (0.005")
Second	86.82	6816	6821	86.89	0.07 (0.003")	86.94	0.12 (0.005")
Third	87.02	6817	6822	87.09	0.07 (0.003")	87.14	0.12 (0.005")
Fourth	87.22	6818	6823	87.29	0.07 (0.003")	87.46	0.12 (0.005")
Fifth	87.42	6819	6824	87.49	0.07 (0.003")	87.54	0.12 (0.005")

Engine Teardown, Primary Side

PRIMARY SIDE (CLUTCH SIDE) TEARDOWN

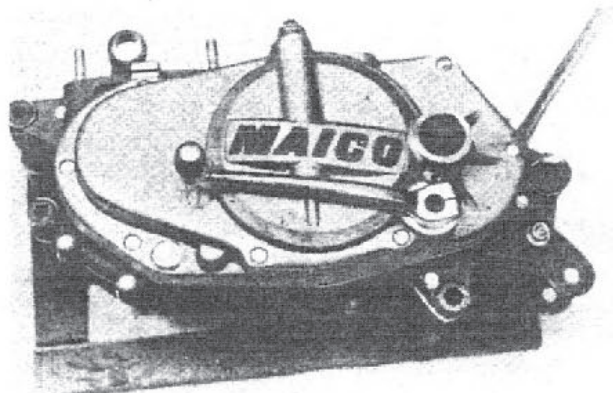
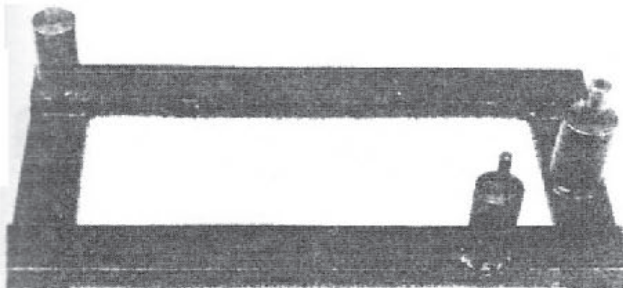

1. It's best to use a standard Maico workstand while tearing down the left side. If none is available, support the engine firmly on a sturdy workbench.

2. Remove all case screws. These are all straight slot. The shift lever does not have to be removed to free the case cover.

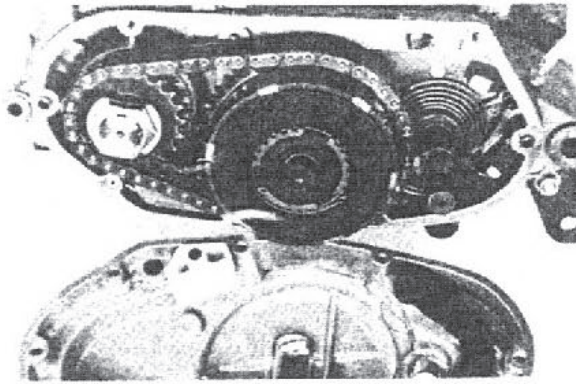

3. Lift off the case cover. In some cases, it may be necessary to tap lightly around the edges with a rubber mallet.

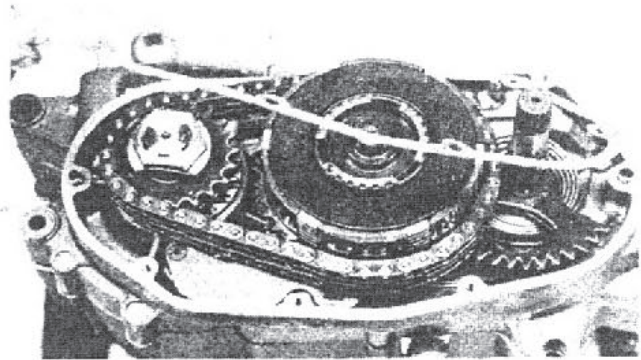

4. Remove the case cover gasket. Discard it. Always use fresh gaskets when working on the engine. Gaskets are cheap and oil leaks are messy and potentially damaging.

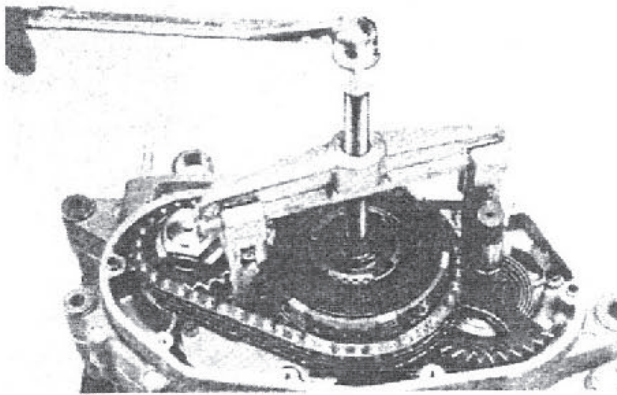

5. Only a few special tools are required to work on a Maico. One of them is a clutch puller. Just about any two or three jaw puller with a good spread will do the job on a Maico clutch. Many riders have used a Sears two-jaw puller (under \$20) for years, with ease and reliability. Others prefer a three-jaw puller. Either way, all you have to do is get something wide and strong enough to compress the clutch. The jaws of the puller should be placed under the teeth of the clutch basket and the tip of the puller should ride on the center of the clutch. Only enough pressure should be applied to let you get at the retaining ring.

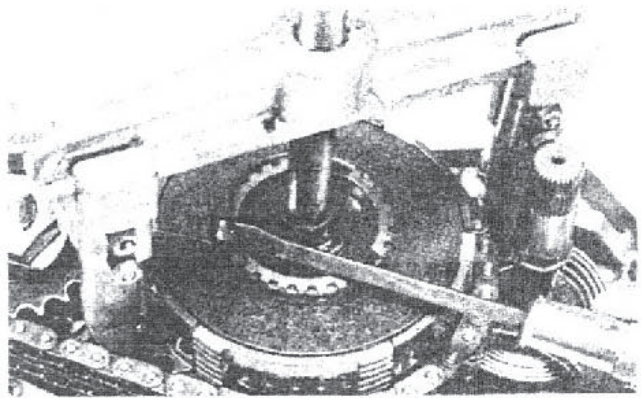

6. The retaining ring can now be pried out. A slender screwdriver can be used.

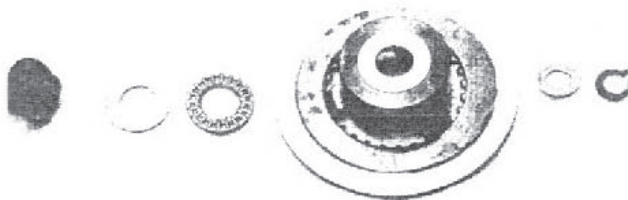

7. Slowly back off the puller and remove it. The entire clutch package can now be lifted out as a unit.

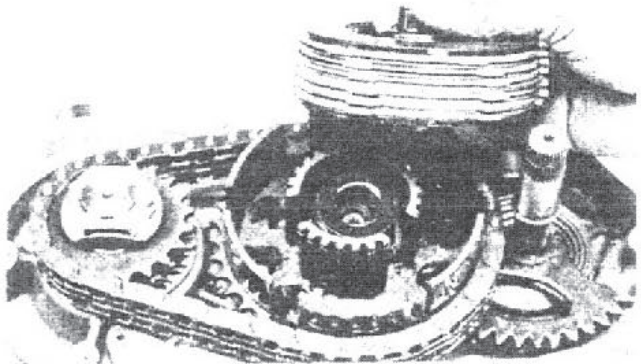

8. Remove the bottom guide plate from the stack of clutch plates. If disassembly is required on the guide plate, here is the correct order of the parts.

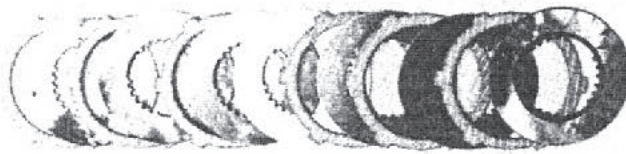

9a Examine the clutch plates for wear or damage. Make sure that they stay in the proper order.

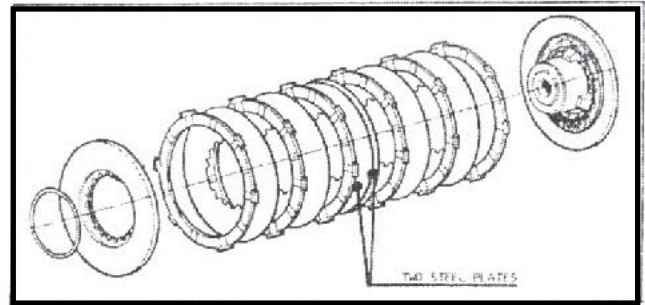

9b Proper stacking order of the clutch and bottom guide plate. Note that all late Maico clutches have two steel plates in the center of the stack.

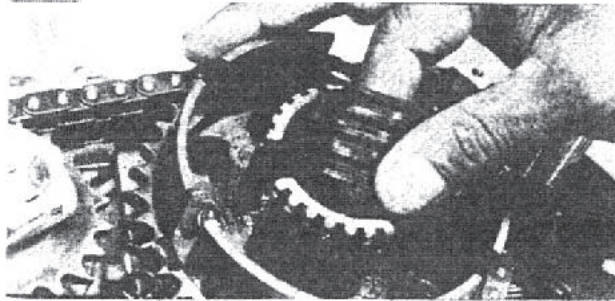

10. The clutch springs can now be lifted out and checked for wear. The total length of a good stack of springs is 28mm. If the measurement is 27mm or less, the springs must be replaced, or clutch slippage may occur.

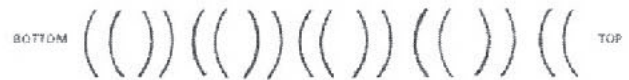

10a Proper stacking order of the clutch springs. There should be 18 springs total.

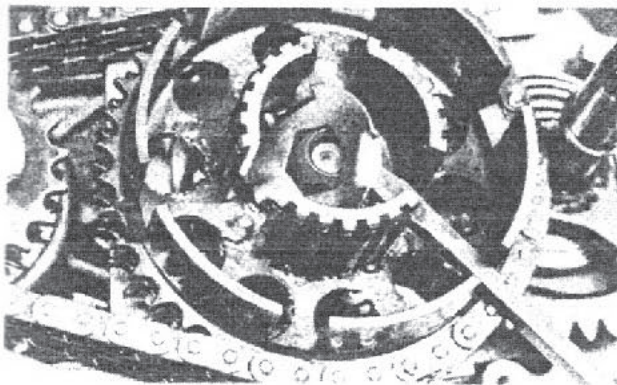

11. Pry up the large locking tab with a flat-tipped screwdriver. Always use a fresh tab.

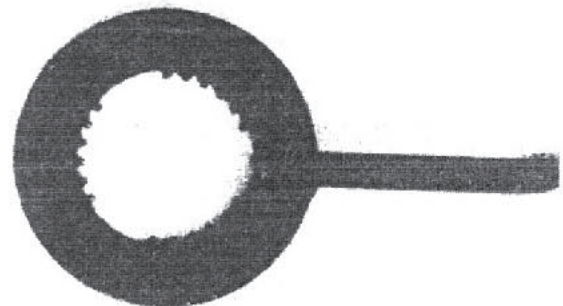

12a. The clutch basket can be held in place with the Maico clutch holding tool.

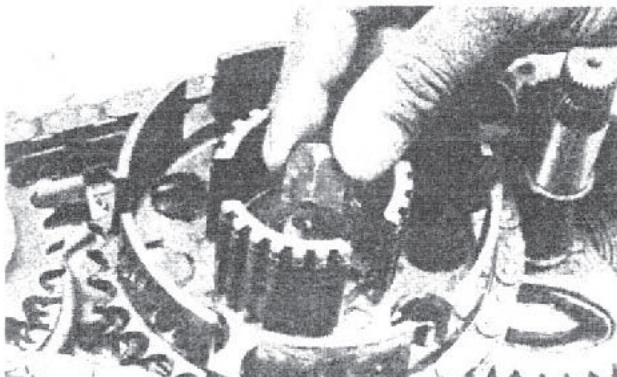

12b. Loosen and remove the nut.

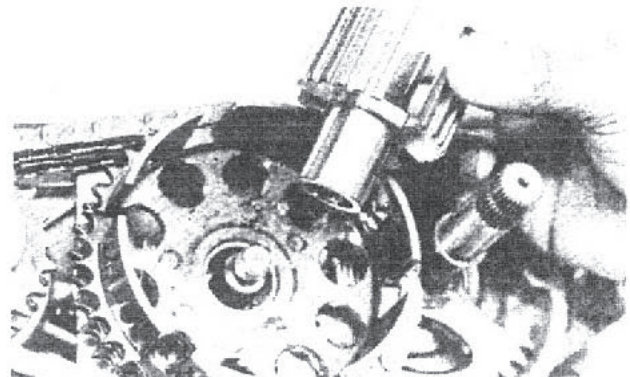

13. Lift out the inner clutch body.

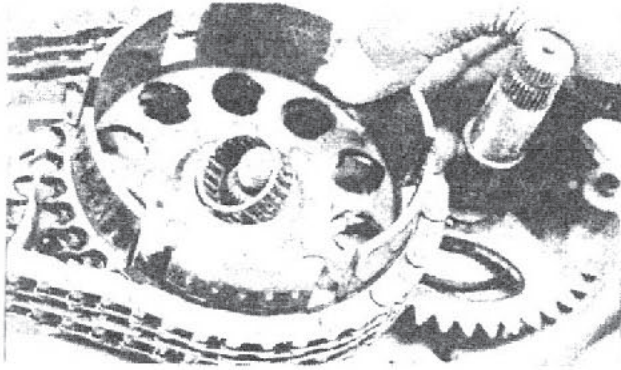

14. In order to loosen the clutch basket for removal, it's necessary to reach down inside and lift out the clutch basket bearings.

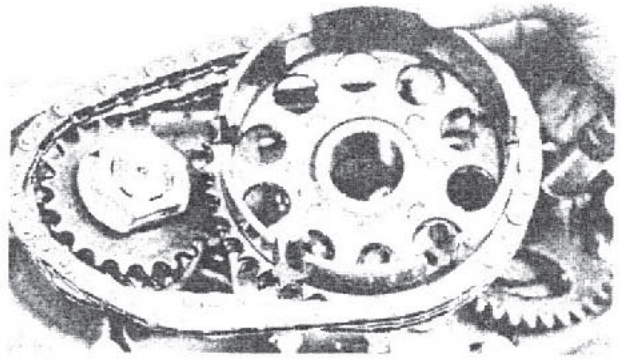

15. The clutch basket can now be lifted off with a rocking motion. Remove one row of primary chain at a time, if necessary. Loose or worn chains will come off easily. Fresh chains will be tighter. Check the chains and the clutch basket for wear or damage at this point.

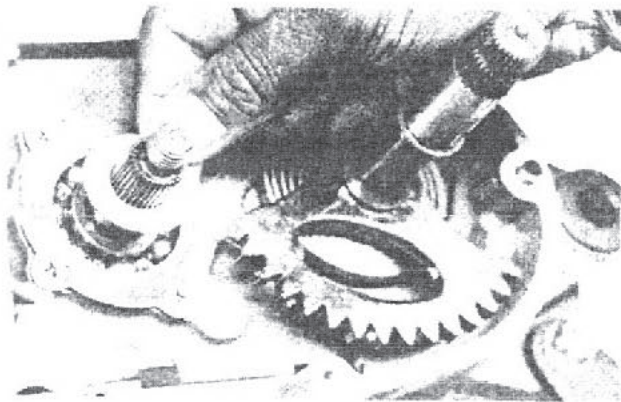

16. Remove the thrust washer that rides directly beneath the clutch basket. Inspect it for wear (grooves indicate wear) and replace if necessary.

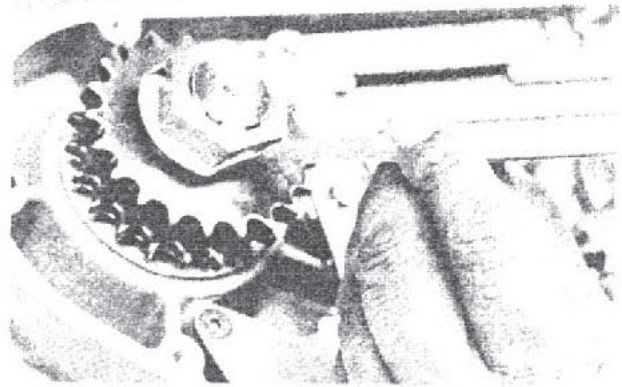

17. Next, pry up the locking tabs on the primary sprocket. A normal chisel will do the job nicely, aided by a few discreet taps from a hammer.

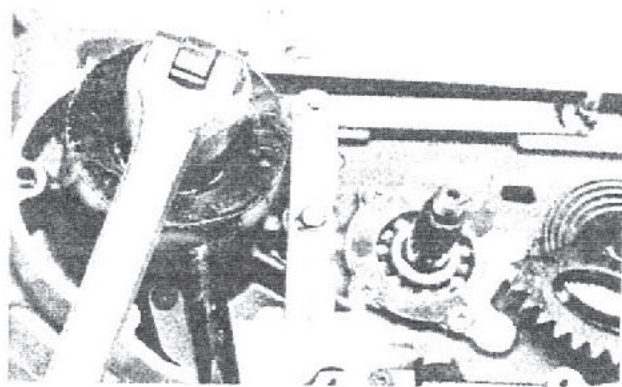

18. Install the primary sprocket locking tool over the primary sprocket. Then, using a 32mm wrench or socket, loosen and remove the sprocket holding nut.

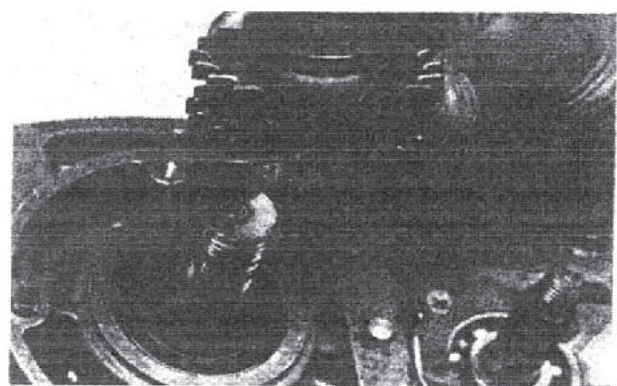

19. The primary sprocket can now be removed and set aside. In most cases it will slip off. If it resists, a puller can easily extract it. Inspect the teeth on the sprocket carefully. If any are hooked badly, chipped, or worn, the sprocket must be replaced. Failure to do so will cause premature and heavy wear on the primary chains and clutch basket.

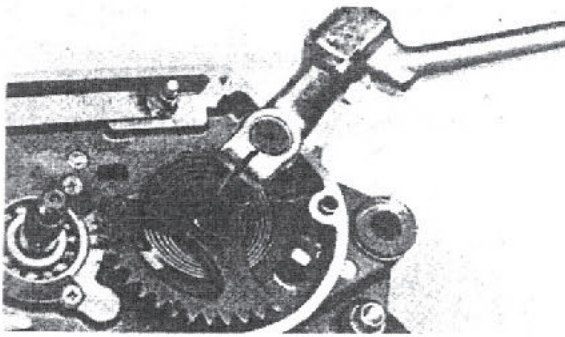

20. To remove the kickstarter spring and pawl, the kickstarter must be slipped in place over the splined shaft. Then, turn the kickstarter slowly and carefully to the left and loosen the spring. After the spring is completely loose, it can be lifted out and set aside.

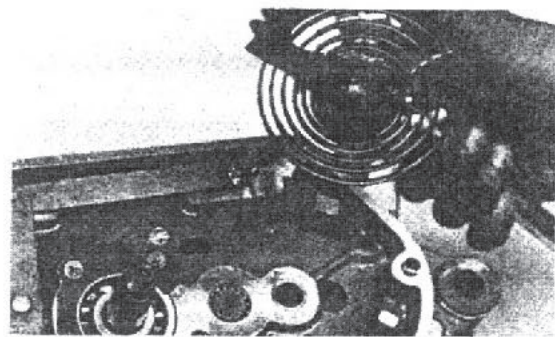

21. The spring and pawl can be lifted out once all the tension has been released on the spring. **CAUTION: THERE IS A GREAT AMOUNT OF FORCE IN A WOUND KICKSTARTER SPRING. USE GREAT CARE WHEN UNWINDING THE SPRING AND KEEP FINGERS CLEAR.**

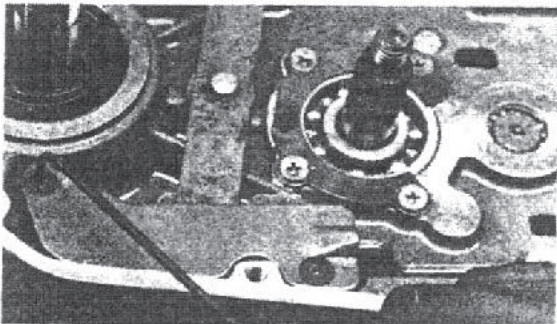

22. Remove hook ratchet cover plate. Two 3mm allen bolts hold it in place. If allen bolts are too tight for easy removal, they've been Loctited in place. Heat may be required to destroy the Loctite bond. **NOTE: - It's not necessary to remove this if you are just splitting the cases. However, if inspection or repair of the whole shifting assembly is required, it's necessary.**

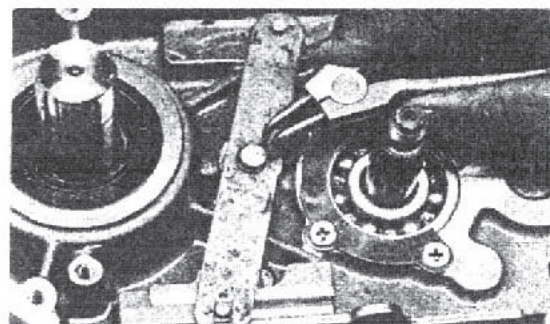

23. Remove shifting pivot pin by detaching small circlip in center.

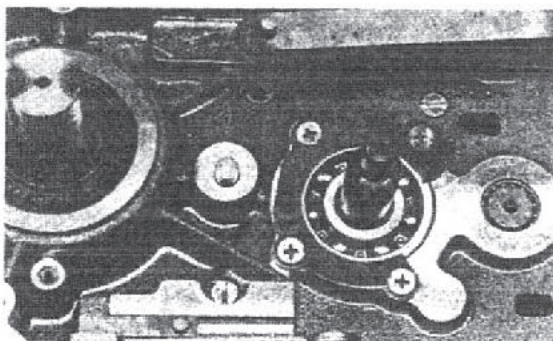

24. Shifting pull rod can now be lifted off.

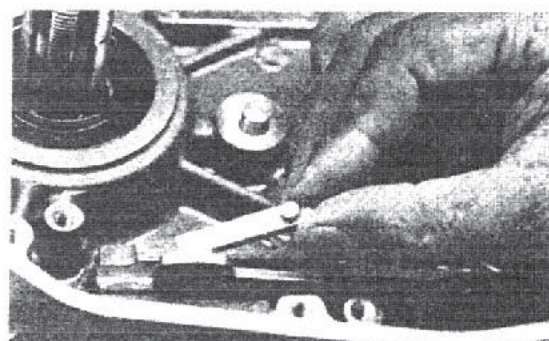

25. Lift the hook ratchet and remove the connecting link.

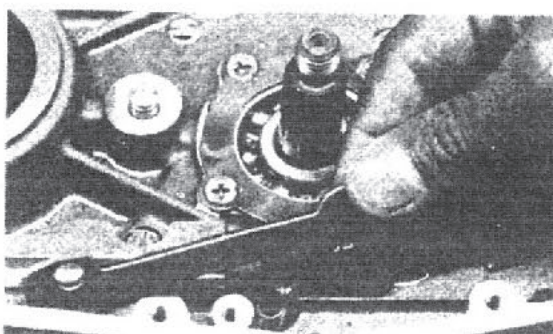

27. The spring must be lifted upward for the hook ratchet to be freed.

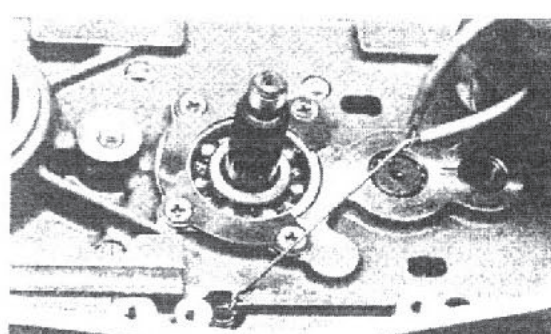

26. Pull up on the hook ratchet. This exposes the connecting spring

Engine Teardown, Splitting Cases, Transmission

SPLITTING THE CASES

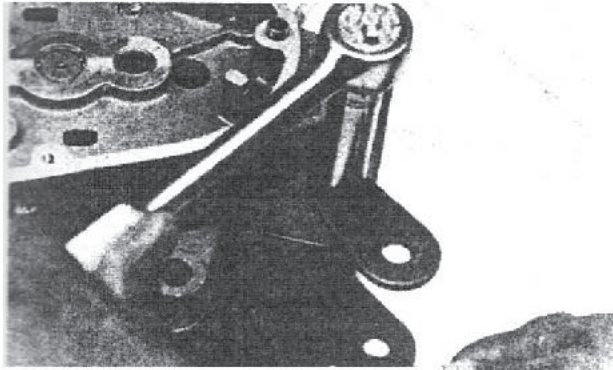

1. Remove shock linkage support brackets.

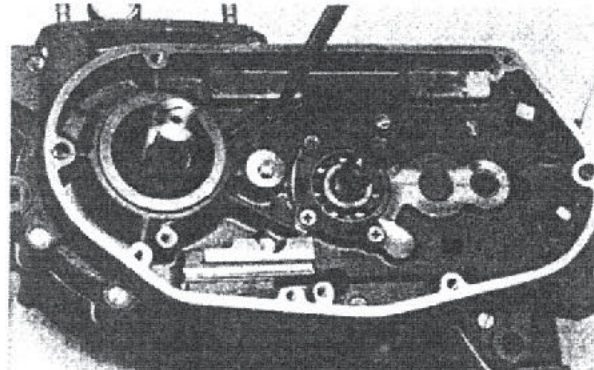

2. Loosen and remove all case screws.

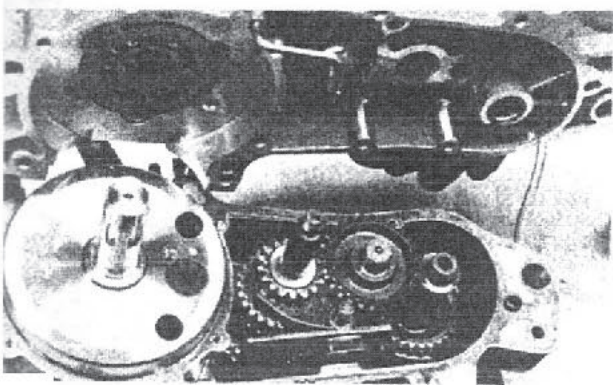

3. The left case half can now be lifted up and removed. Light tapping with a rubber mallet may be required. Remove the gasket and discard. Always use a fresh gasket to prevent oil leakage.

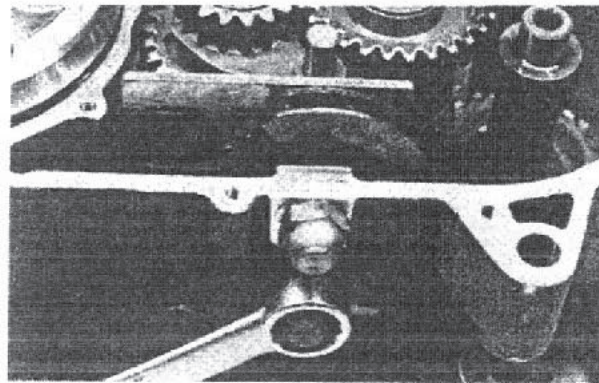

4. Using a 19mm wrench, remove the detent pin.

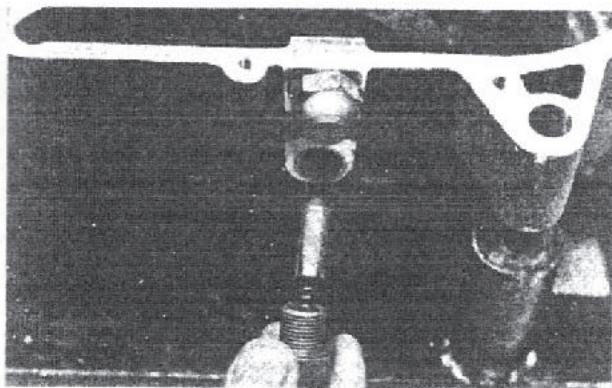

5. This is the heart of the Maico transmission. If it's worn, it must be replaced. Do *not* attempt to regrind it. This is important.

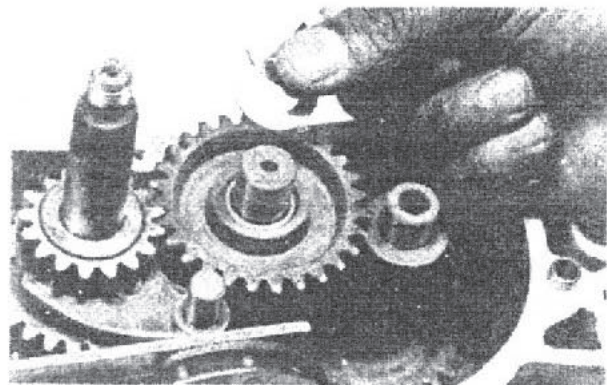

6. Remove the two thrust washers on the layshaft. They are 1mm and .8mm in thickness.

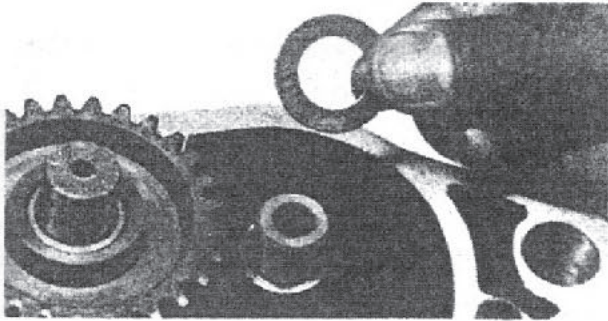

7. Remove the washer from the countershaft. It's 1mm thick.

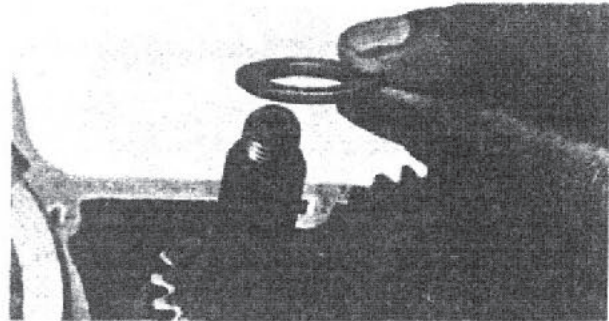

8. Lift off the 3mm washer from the mainshaft.

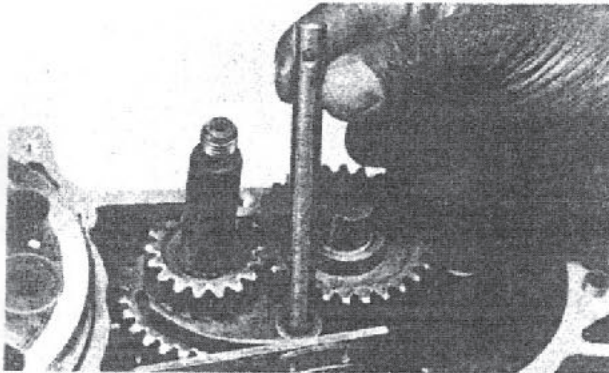

9. Lift out and remove the shifting fork spindle.

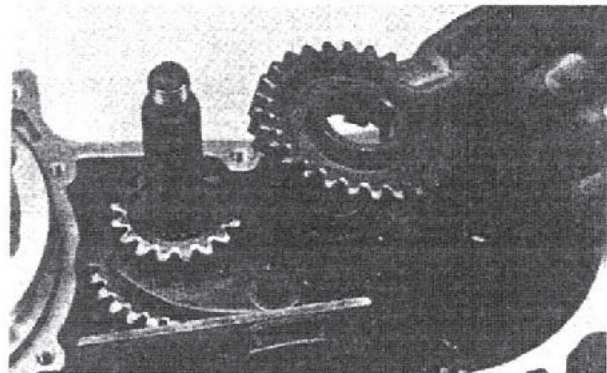

10. Remove first gear from the layshaft.

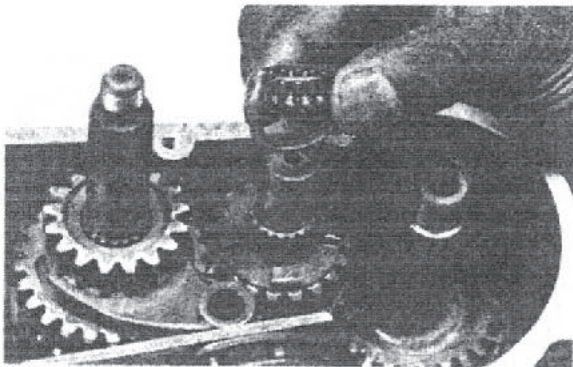

11. Lift out the needle bearing and the 1mm washer from the layshaft.

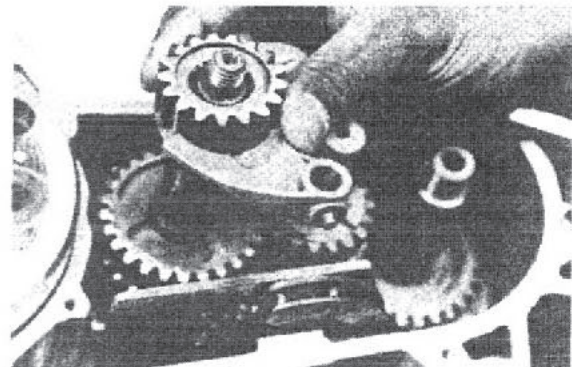

12. Remove first gear from the mainshaft *with* the shifting fork.

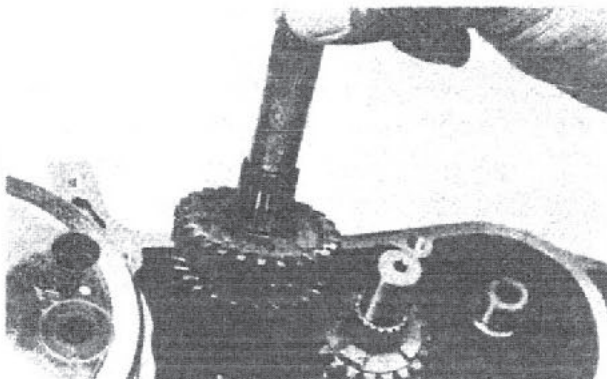

13. Lift out the mainshaft *with* the attached gears.

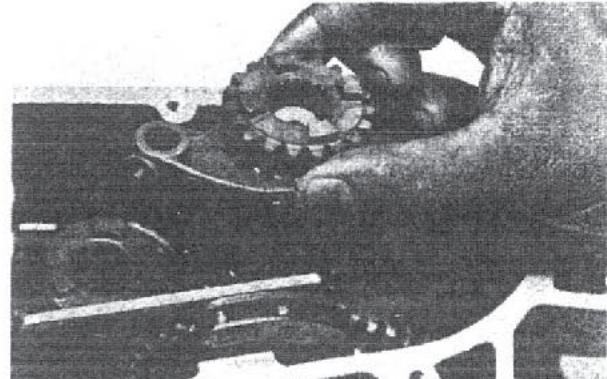

14. Remove the twin block from the layshaft *with* the shifting fork.

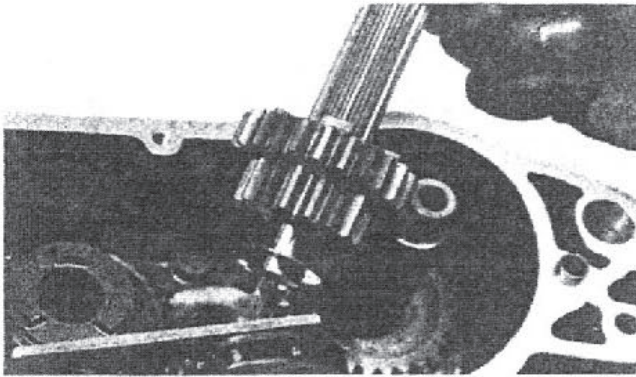

15. Now the layshaft can be lifted out *with* the attached gears. A 1mm washer is on the shaft at the bottom of the stack.

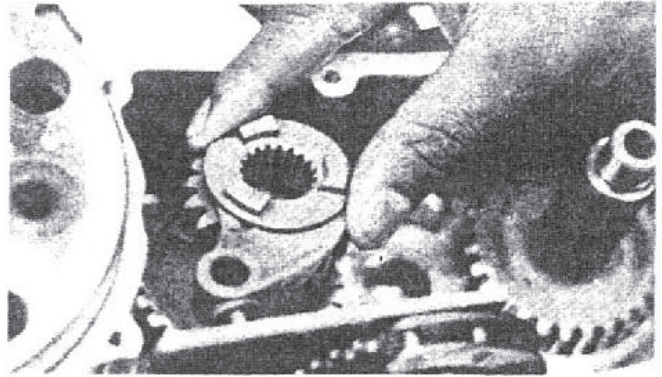

16. Remove second gear on the mainshaft.

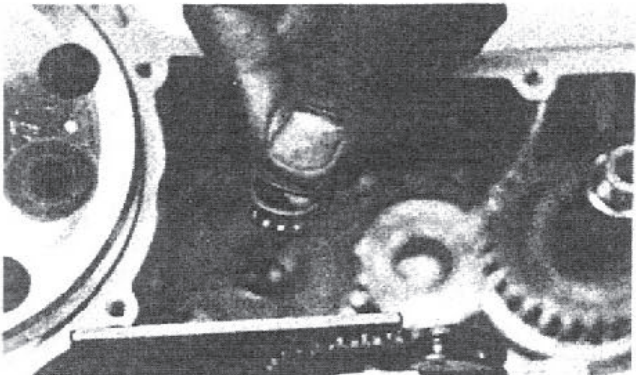

17. Lift out the washer from the top of fifth gear (on the mainshaft) and then remove the needle bearing beneath it.

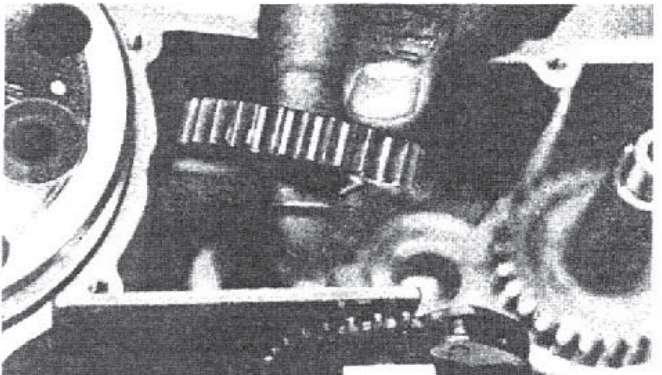

18. Fifth gear on the mainshaft can now be lifted out. Also take out the 1mm washer under the gear.

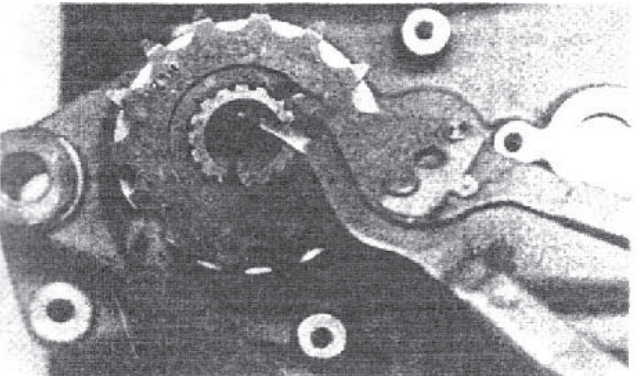

19. Turn the case over and remove the circlip from the countershaft sprocket.

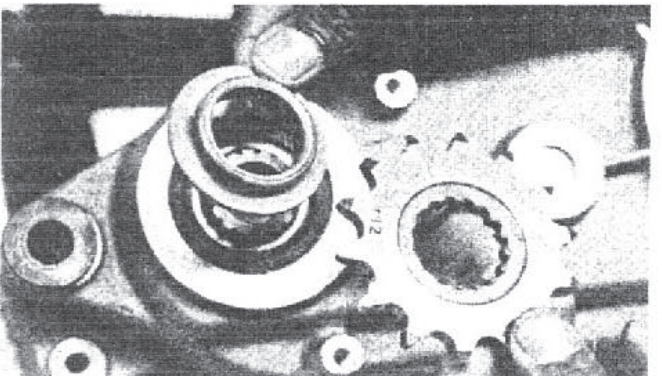

19a. A spacer is under the countershaft sprocket.

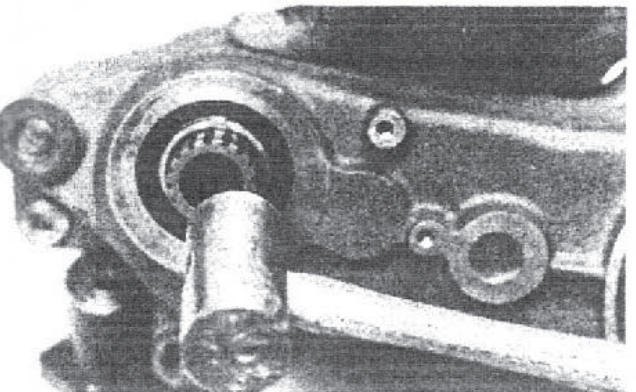

20. Tap out the countershaft, if needed.

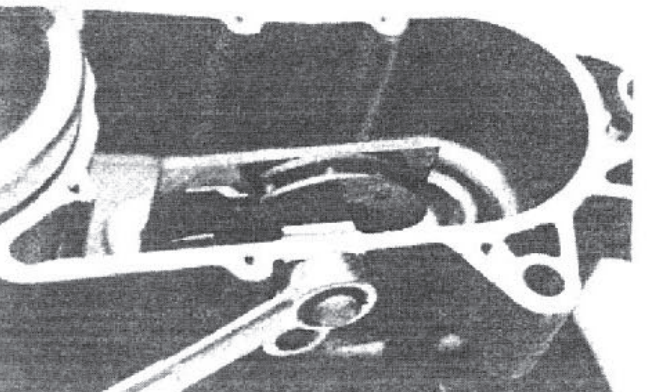

21. Remove the shifting cam bolt with a 19mm wrench.

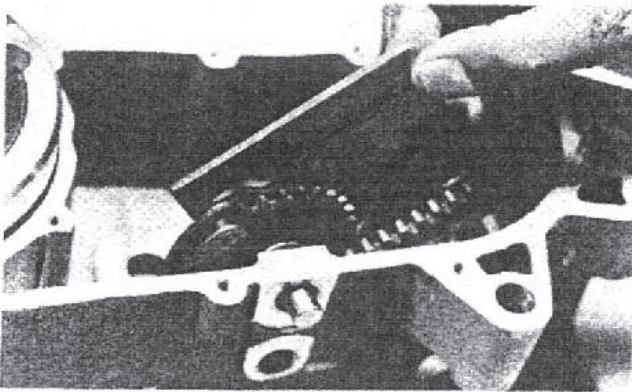

22. The shifting plate can be lifted out and removed.

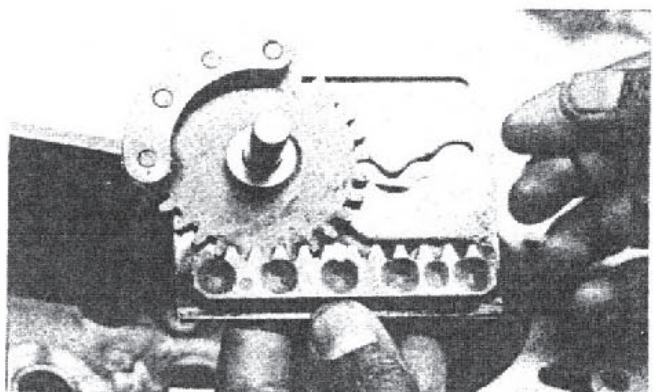

23. NOTE: — The dot on the shifting segment gear *must* line up with the second slot.

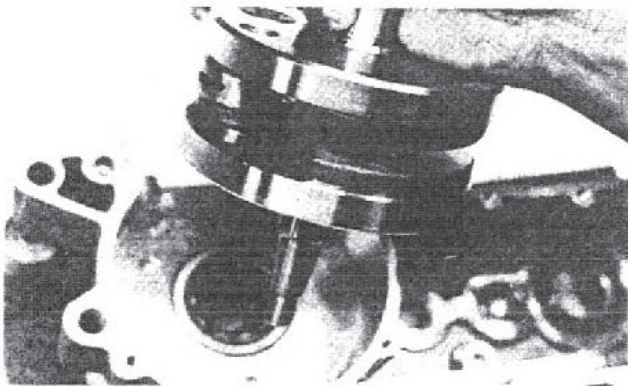

24. The crank can be lifted out at this point. No special tools are needed for this.

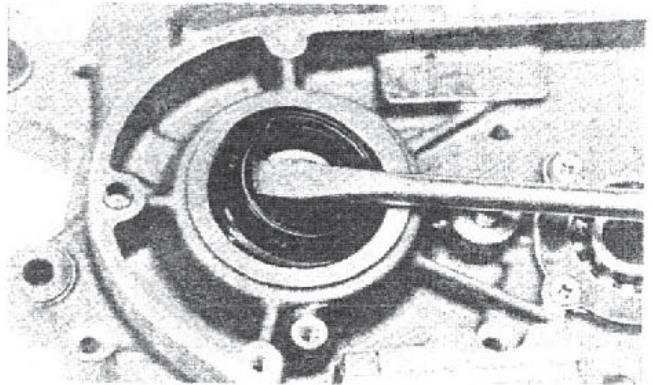

25. To remove the left case main seal, simply pry it out with a flat-bladed screwdriver. Do not re-use main seals.

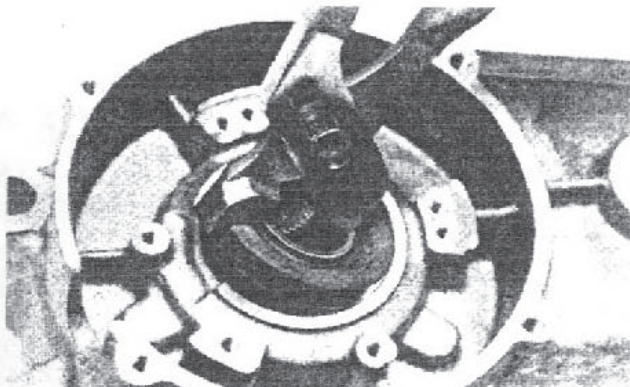

26. The right side main seal can be pried out easily with a pair of channel locks.

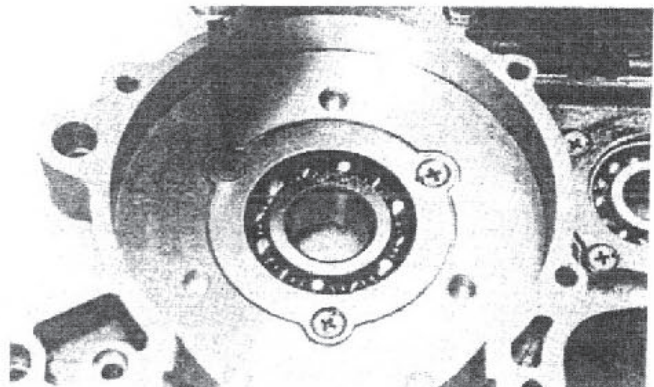

27. Before removing the left case main bearing, you must remove three screws and a holding plate. The case should be heated before the bearing is tapped out. When reinstalling the left case seal, heat must be used again and the special Maico tool must be used to seat the bearing at the proper depth to keep the seal lip from rubbing against the crank bearing. After the bearing cover is secured back in place, lock the screws with punch marks.

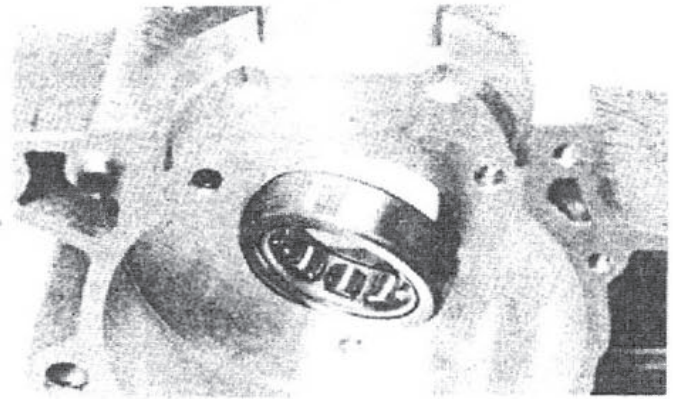
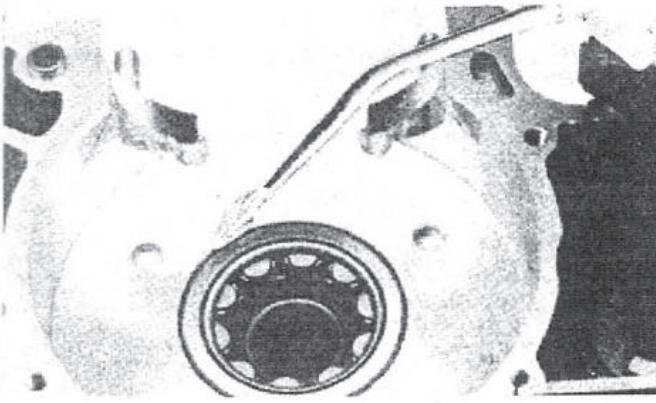

28. For the right side case main bearing, heat the case and tap it out. To reinstall the bearing, heat the case and tap it until it seats firmly.

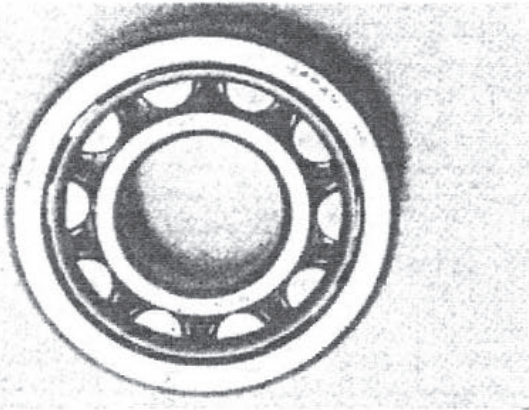

29. The crank has bearings matched to the inner race, and they are hand marked after the regular number. Example: NU305 C3 - (1) or (2). The inner bearing must have the same mark. You must use a matched set.

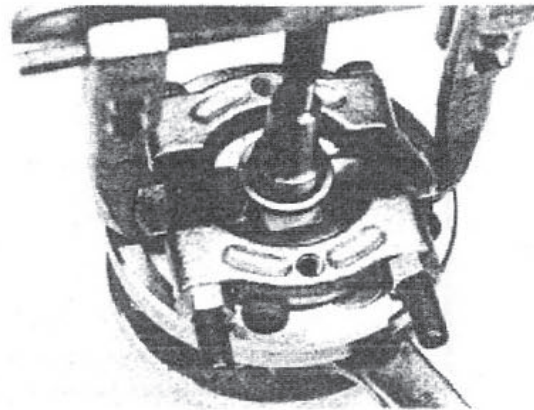

30. The inner bearing must be heated, then pulled off. Use a standard two-jaw bearing race puller. Snap-On makes a good one.

250 CASE STUFFER VARIATION

The 250 Maico lower end differs from the 490 in that it has a set of magnesium crank stuffers to reduce the volume in the crank area. To remove these stuffers for case service, follow this sequence.

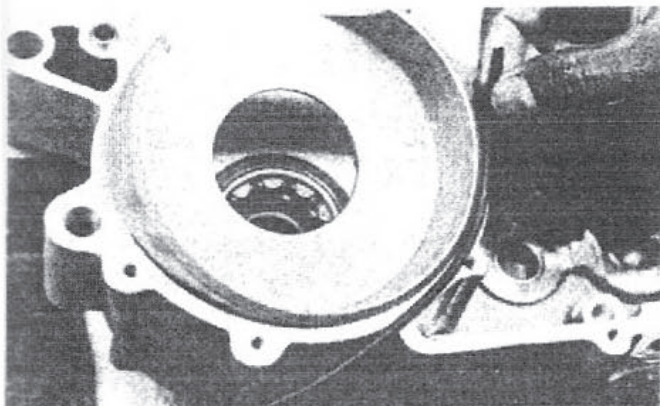

1. Pull out the crankshaft. Then, pull out the half O-ring from the magnesium stuffer.

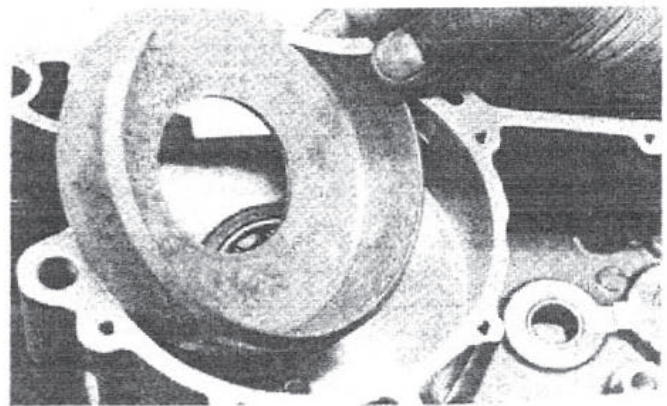

2. Lift mag case stuffer from case half. Do not re-use the O-ring. Replace the ring every time it's removed.

Transmission Layout Chart

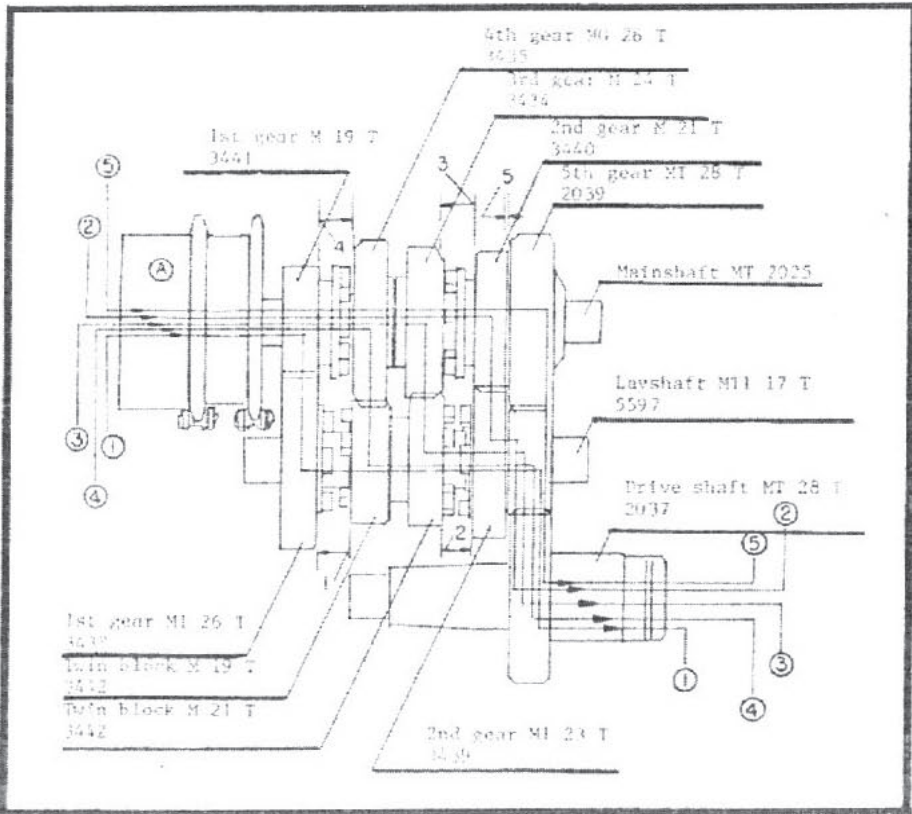
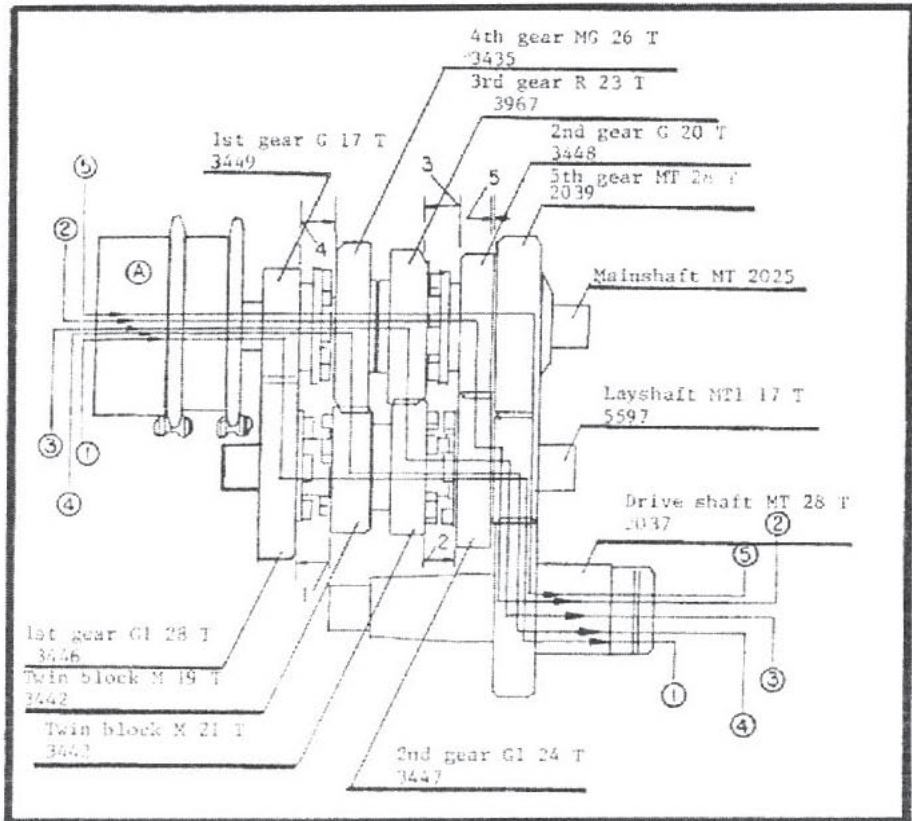

Crank/Rod Set-Up

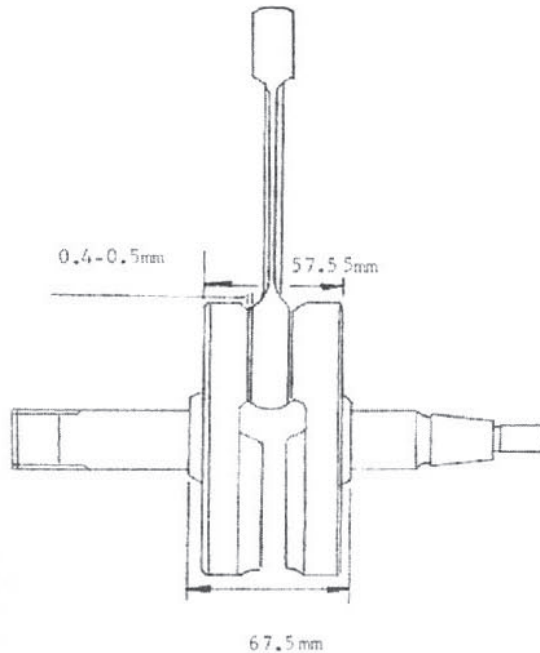

250 Tolerances

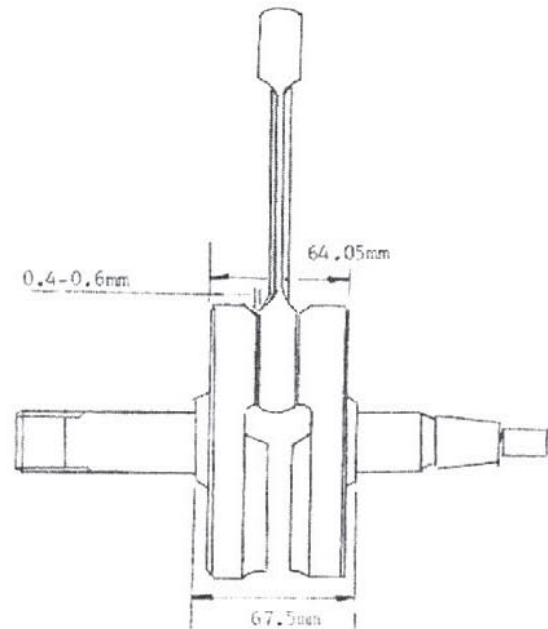

490 Tolerances

Engine Reassembly

REASSEMBLY: GENERAL INFORMATION AND GUIDELINES

1. When reassembling the engine, make sure that all parts have been thoroughly cleaned. It's also a good idea to lay out all of the parts on a clean, flat area. A large white towel makes an ideal assembly base.
2. Keep your manual handy and refer to the torque values for the various nuts, bolts and screws. Never re-use a nut, bolt or screw that has damaged threads, or is bent or deformed in any fashion. Do not use any fasteners that have obvious rust or corrosion build-up.
3. Always use fresh gaskets and lock tabs throughout the engine. When installing new seals, it's best to grease them lightly with a high-quality graphite or assembly grease to avoid premature wear or damage.
4. Always use clean tools. Keep your hands and your work area clean. A careful, meticulous, workmanlike manner will give you a sense of pride and guarantee a sound racing engine upon completion.

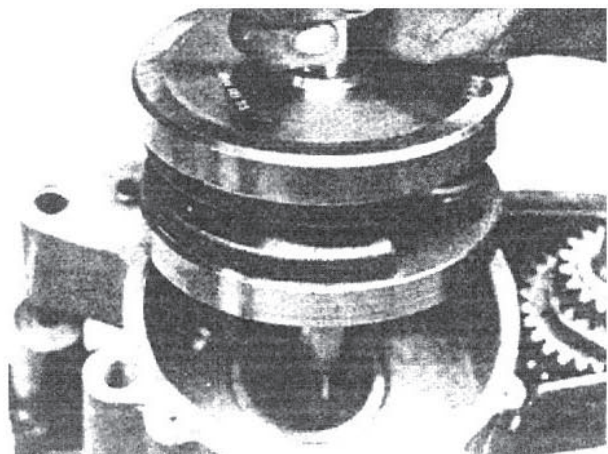

SPECIAL REASSEMBLY NOTES

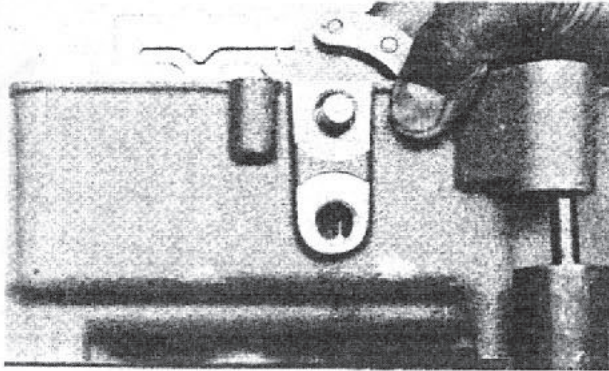

1. When lining up the shifting plate, the small (neutral) detent selector hole must line up with the hole, with the plate inserted. The plate can then be locked in place and the detent selector pin tightened home. This is important!

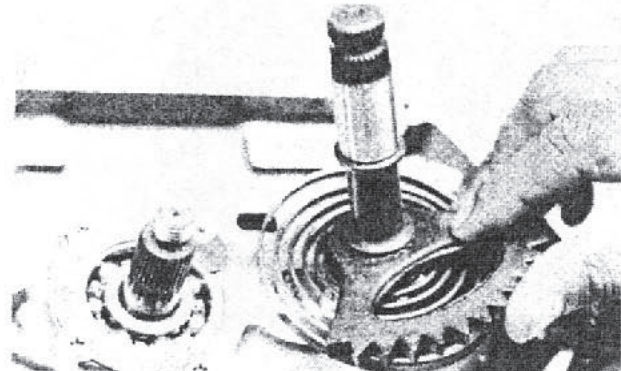

2. When rewinding the kickstarter return spring in place, it can be started by hand, then the kickstarter should be placed over the shaft. Use care when winding and use a rocking motion to keep the spring from climbing up while tightening.

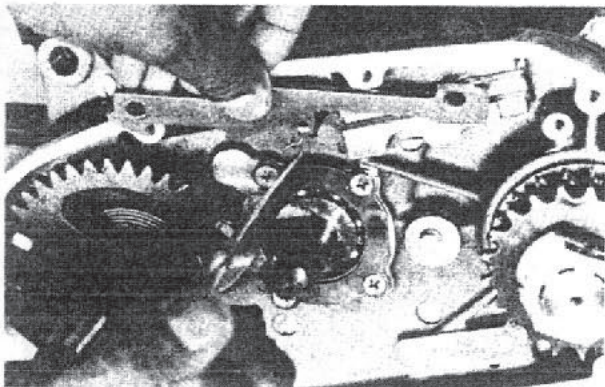

3. It will be necessary to use a spring tool to hook the spring back on the sliding selector pawl.

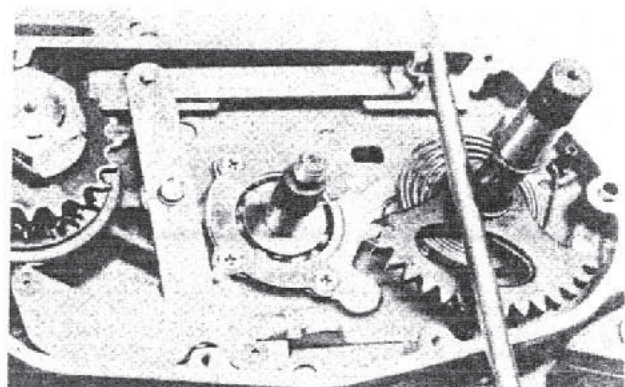

4. CHECKING GEARBOX FUNCTION BEFORE FINAL ASSEMBLY. In order to make sure that all gears are working properly, you can perform a simple bench check before the case cover is bolted in place. The shifting segment can be moved by using a screwdriver. Then, spin the mainshaft and run through the gears. Check each gear for engagement, both up and down and ensure that neutral can be located between first and second gear. Once all gear operations have been verified, you can now proceed with closing up the case cover.

CAUTION:— ON THE 250 ENGINE, SPECIAL CARE SHOULD BE TAKEN NOT TO SNAG THE RING IN THE INLET.

NOTE:— DO NOT OIL THE BARREL LINER AND THE PISTON ASSEMBLY. THIS IS WRONG. A TOP END SHOULD BE ASSEMBLED DRY. THE PRESENCE OF OIL IN THE COMBUSTION CHAMBER WHEN THE BIKE IS INITIALLY FIRED CAN CAUSE GLAZING ON THE CYLINDER WALLS AND MAY CAUSE THE RINGS TO STICK IN THE RING LANDS. THE OIL IN THE PRE-MIX IS MORE THAN SUFFICIENT FOR ENGINE LUBRICATION. THIS IS IMPORTANT.

TIMING PROCEDURE

Insert a dial indicator into the spark plug hole. Bring the piston up to Top Dead Center (TDC) and set the gauge to zero. Rotate the crank back, bringing the piston to the desired point:

- 250cc engine — 1.8mm Before TDC
- 490cc engine — 2.1mm Before TDC

At this point, the marks on the rotor and the stator must line up. If they do not, the stator can be rotated until they line up. Tighten up the stator and recheck the timing. Timing must be accurate to within 0.1mm. Check the magnet nut for proper torque (47 foot-pounds) left handed thread.

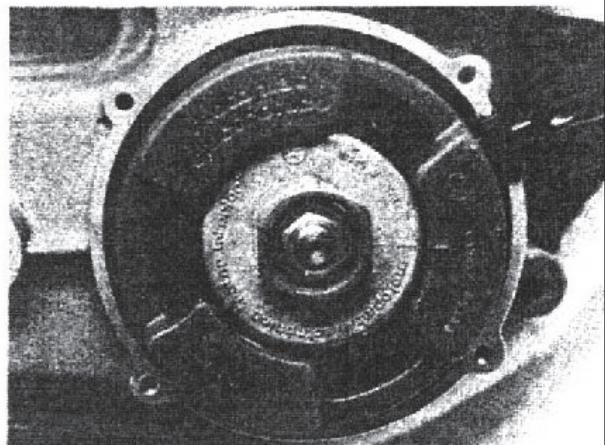
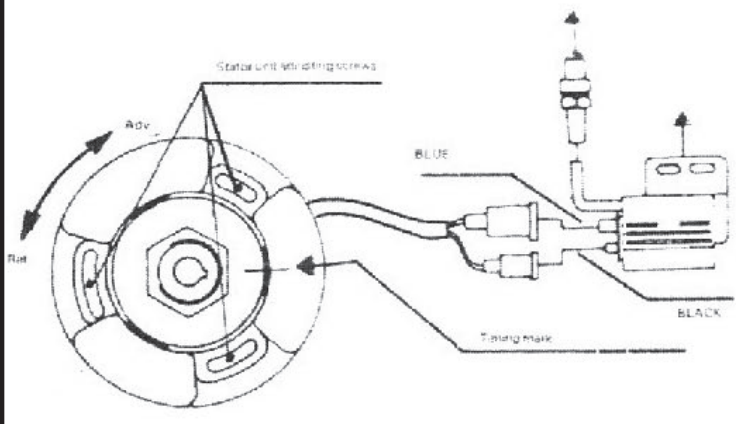

CYLINDER DECK HEIGHT AND BASE GASKET

It is necessary to check the deck height of the cylinder to prevent abnormal combustion, preignition, and knocking noise of the engine. An irregularly running engine will cause the piston and cylinder to overheat. This condition is suspected of having an adverse effect causing seizure, cylinder head damage, and lean mixture. The deck height is measured from the cylinder sleeve head gasket surface (without head gasket) to the top edge of the piston ring. The proper measurements for best performance of the engine are not less than 0.4mm and not more than .65mm. In order to achieve the proper height, use different thickness of base gaskets.

Part Number 6793	Base gasket—0.3mm thickness
Part number 6794	Base gasket—0.5mm thickness
Part number 6795	Base gasket—0.7mm thickness

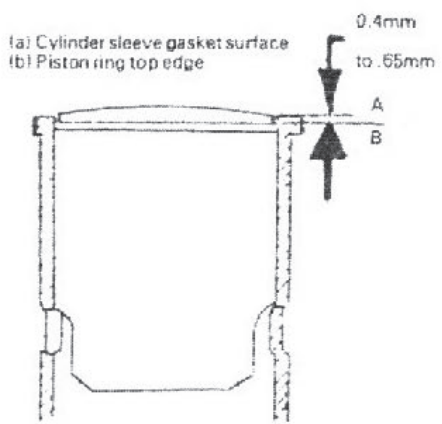
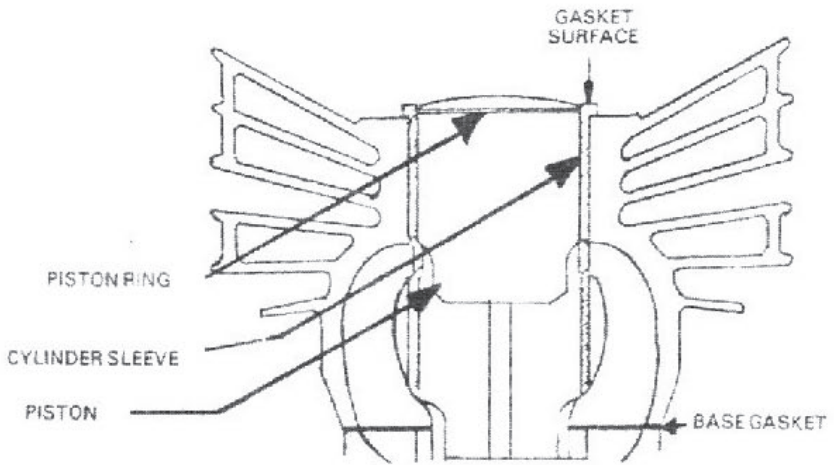

Trouble-Shooting Chart

SYMPTOM/ MALFUNCTION	POSSIBLE CAUSE		SHIFTING
		Reluctant, or stiff shifting	<p>SHIFTING</p> <ul style="list-style-type: none"> Warped clutch plates. Sacked clutch springs. Low oil level. Shifter rubbing against case. Worn or deformed shift fork. Worn pawl pin. Worn pawl pin spring. Broken or badly worn gearshift return spring. Worn or chipped gear dogs. Broken gear teeth. Worn or rounded gear teeth.
	ELECTRICAL SYSTEM		
Fouled spark plug (wet/black)	Clean or replace, possible rejetting needed.		
Engine fails to start	<ul style="list-style-type: none"> Check spark plug for spark. Check all electrical leads for clean and tight connections and possible corrosion. Check kill button, disconnect wire to kill button and recheck spark. Check for moisture in plug cap or electrical circuit. Coil or plug wire may be burned, or grounded out on pipe or frame. Faulty ignition system or bad coil. Poor ground at coil. Grossly incorrect timing. Leaking seal on right side of crank case leaking oil into electrics. Wire from ignition to coil may be shorted (grounded). 		
Engine runs erratically	<ul style="list-style-type: none"> Spark plug may be breaking down. Possible incorrect ignition timing. Loose wires or connections in electrical circuit that are affected by vibration. Loose screw-on tip and spark plug. Loose kill button wire. Water present in electrical system. Intermittent shorting, or grounding out. Ignition system faulty (breaking down of coil, etc.; bench check can verify.) 	Wheels and chassis	<p>VIBRATION</p> <ul style="list-style-type: none"> Wheels out of balance. Wheels out of true. Bad wheel bearings. Steering head bearing loose or worn. Swingarm pivot loose. Swingarm bearings worn. Front or rear axle bent. Loose triple clamps and bar clamps. Loose exhaust pipe mounting.
		Engine	<ul style="list-style-type: none"> Loose engine mounts/bolts. Loose clutch bearings. Loose head steady. Unbalanced crank (unlikely). Worn piston/rings. Grossly leaking head or base gaskets. Badly worn primary chain. Broken tangs on clutch basket. Worn crank bearings. Loose or worn swingarm bearings.
	FUEL AND CARBURETION SYSTEM		
Engine fails to start	<ul style="list-style-type: none"> No fuel in tank (dummy!). Fuel tap not turned on. Vent in gas cap plugged, preventing flow of fuel. Petcock plugged, no gas flow. Carburetor jets blocked with foreign matter; no flow. Float inlet needle stuck in place; no fuel to float bowl. Engine cases loaded up with gas, usually caused by faulty float needle, letting gas into lower end of bike. Float level far too high, allowing raw gas to flow into engine. Major air leaks, i.e., carb cap off, broken manifold, etc. 	Slipping	<p>CLUTCH</p> <ul style="list-style-type: none"> Worn plates. Improper adjustment of cable. Cable binding. Warped plates. Warped plates. Low oil level. Incorrect cable adjustment. Improperly stacked clutch springs.
Engine runs erratically	<ul style="list-style-type: none"> Improper jetting; too rich or too lean at various carb circuits. Jets may be clogged, or water may be present in system. Sediment in system may be drawn into jets in an intermittent fashion. Float level may be incorrect. Engine mount bolts may be loose, allowing excessive vibration and sloshing of gas into lower end. Gas cap vent may be clogged. Fuel petcock may be clogged. Too much oil in gas. Pilot air screw improperly adjusted. Carburetor loose in clamps. Top of carb (carb cap) loose. Deteriorated fuel (stored too long). 	Dragging	
		Engine does not run / will not start	
	AIR LEAKS / CONNECTIONS		
Engine runs erratically	<ul style="list-style-type: none"> Carb is loose in clamps. Cap of carb is loose. Air boot or manifold is cracked or not seated properly. Faulty seal on tight side of crank. Porous casting in engine cases (unlikely). Improperly seated gasket in cases. Dirty air filter. Collapsed air boot between carb and air box. Faulty head gasket. Faulty base gasket. Loose spark plug. Loose head pipe on exhaust. Cracked head pipe, or cracked, smashed exhaust pipe. 	Engine runs erratically	<p>MECHANICAL</p> <ul style="list-style-type: none"> Seized piston. Rings stuck in piston lands. Broken rings. Holed piston. Foreign part or broken part in combustion chamber, or lower end. Broken spark plug tip. Rod failure. Top end bearing seizure. Lower end bearing seizure. Broken center case. Gasket failure in cases. Reed valve failure (250 only). Broken piston skirt. Collapsed or plugged exhaust system. Worn piston and/or rings. Rings stuck in lands. Broken rings. Excessive ring end gap. Excessive carbon build-up. Faulty gaskets, center case. Leaking head gasket. Leaking base gasket. Carb or intake tract loose. Reeds deteriorating (250 only). Cracked or smashed exhaust. Clogged exhaust system/muffler.

Specifications

1982 MAICO ALPHA SPECIFICATIONS

	250cc	490cc
DIMENSIONS		
Overall length	2190mm (86.22 inches)	—
Overall width	650mm (33.5 inches)	—
Seat height	960mm (37.8 inches)	—
Wheelbase	1510mm (59.46 inches)	—
Ground clearance	372mm (14.64 inches)	—
Weight, dry (no oil or gas)	372mm (14.64 inches)	—
Weight, dry (no oil or gas)	104 kg (227 pounds)	105 kg (231 pounds)
Weight, fully gassed, ready to race	245 pounds	249 pounds
ENGINE		
Engine type	Air-cooled, two-stroke, single, read-valved	Piston port valving
Actual displacement	247cc	488cc
Bore and stroke	67mm x 70mm	86.5mm x 83mm
Compression ratio	12:1	12:1
Clutch	Multiplate, oil bath, six sinter plates and six steel plates	—
Transmission	Five-speed gearbox, left side shift	—
Gear ratios:		
First	2.25 (20.51)	2.71 (20.15)
Second	1.80 (16.44)	1.97 (14.69)
Third	1.44 (13.13)	1.50 (11.17)
Fourth	1.20 (10.96)	1.20 (8.94)
Fifth	1.00 (9.11)	1.00 (7.43)
Primary reduction ratio	41/18 = 2.28	39/21 = 1.86
CARBURETION		
Carb type and size	Bing, type V54/2.1, 38mm	Bing, V54/2.2, 40mm
Main jet	190-195	185 or 190
Jet needle	6D2	6L2
Needle jet	278-2	280-2
Cutaway (side no.)	210-3	220
Pilot jet	55 to 65	50 or 55
Air screw, turns out	approx. 1 1/2 turns out from seated	Approx. 1 1/2 times
Float level	Parallel to base of carb body	—
CHASSIS		
Frame type	Double downtube, full cradle, chromoly steel tubing	—
Steering head angle	28.5 degrees	—
Trail	372mm (14.96 inches)	—
Head bearing type	Sealed tapered roller bearings	—
Type of steel	chromoly tubing	—
Swingarm bearings	Needle bearings sealed with O-rings	—
FRONT SUSPENSION		
Type	Telescopic, 42mm tubes, air/oil, forward axle	—
Fork travel	310mm (12.2 inches)	—
Fork spring, free length	225mm	—
Fork oil quantity, basic	535cc	—
Fork oil, type/viscosity	Five or 10 weight, Bel-Ray or LT100 Bel-Ray	—
Air pressure, basic	Between 8 and 14 psi	—
Fork oil level height, from top	170mm (6 1/2 inches)	—
REAR SUSPENSION		
TYPE	Alpha 1, single Corte & Cosso shock	—
Damper type/description	Pressurized reservoir, gas shock, adjustable rebound damping	—
Gas pressure	Between 218 and 225 psi	—
Gas type, suggested	Nitrogen gas	—
Shock spring free length	255mm (10.03 inches)	—
Set length	235mm (9.25 inches)	—
Spring rates	12.4 kp, stock	—
	Optionals: 12.3 kp and 12.5 kp	—
Rear wheel travel	325mm (12.8 inches)	—

Shock length	474mm (18.66 inches)	—
Swingarm, allowable deflection	smooth rotation, no side play	—
Minimum spring preload	1mm	—
Rebound damping adjustments available	60	—
Rebound click, rec'd basic number	25-30	—
WHEELS, BRAKES		
Tire size, type, front	3.00 x 21, two-ply Metzeler	—
Tire size, type, rear	4.50 x 18 two-ply Metzeler	—
Pressure, front, normal, two-ply	15 psi	—
Pressure, front, normal, four-ply	10-12 psi	—
Pressure, rear, normal, two-ply	15 psi	—
Pressure, rear, normal, four-ply	10-21 psi	—
Rim type, front and rear	Aluminum alloy, shouldered, gold anodized	—
Rim size, front	1.6 x 21	—
Rim size, rear	2.15 x 18	—
Maximum allowable rim runout:		
Vertical	2mm (0.08 inch)	—
Horizontal	2mm (0.08 inch)	—
Front brake, type	Drum, twin shoes, cable operated	—
Brake drum I.D., front	136mm (5.3 inches)	—
Brake shoe, front, width	25mm (1.0 inch)	—
Rear brake, type	Drum, twin shoes, rod operated	—
Brake drum I.D., rear	160mm (6.2 inches)	—
Brake shoe, rear, width	30mm (1.18 inches)	—

ALPHA E (ENDURO MODELS) SPECS VARYING FROM MX MODELS

	250cc	490cc
Dry weight	238 pounds	240 pounds
Exhaust system	High-pipe with aluminum silencer/spark arrester	—
Ignition system	Bosch pointless, with lighting oil	—
Final drive ratio	52/13 = 3.71	—
Type of gear	GT-1	—
GEARBOX RATIOS:		
First	2.98 (25.2)	—
Second	2.17 (18.35)	—
Third	1.65 (13.95)	—
Fourth	1.00 (8.45)	—
Fifth	1.25 (10.6)	—
Drive chain	112 links	—
Gas tank capacity	13.25 liters (3.5 gallons)	—
Headlight	35 watt/ 12 volt	—
Brakelight	24 watt/ 12 volt	—
Taillight	6 watt/ 1 volt	—

WEAR LIMITS SPRING/CLUTCH

	STOCK	SERVICE LIMIT
FRONT FORK SPRING		
Standard spring length	590mm	575mm-580mm
Spring diameter	4.2mm	—
Spacer length	34mm	—
CLUTCH		
Clutch spring	28mm	26.5-27mm
Clutch plates sinter	3mm	2.95mm
Clutch plates metal	1mm	Replace when bent .090mm to 0.095mm
Pressure plate	1.5mm	If the circlip grooves are worn to 1.0mm
Circlip Groove	—	—

Technical specifications are subject to change without notice.

BEARING INFORMATION

ENGINE/BEARING SIZE	SERVICE LIMIT MAICO PART NO.
Main bearing, LH—ball bearing 3305 C3	693
Main bearing, RH—roller bearing U305 C3	426
Top end bearing—needle bearing 18-22-24, 0-2, 0-4, 0-6 tolerance	424
Crankshaft bottom end bearing—(see crankshaft measurements)	—
TRANSMISSIONS AND BEARINGS IN THE ENGINE CASE	
Main bearing on the mainshaft, LH—ball bearing 6303 C3	339
Main bearing on the mainshaft, RH—closed caged needle bearing, BK1616	514
Layshaft bearing, LH—open caged needle bearing, RNA 4901	5506
Layshaft bearing, RH—open caged needle bearing, INA NK 16/16 B	5598
Drive shaft bearing, RH—ball bearing, 6206 2 RS C3	375
Drive shaft bearing—open caged needle bearing, HK 1612	513
TRANSMISSION BEARINGS	
Bearing on the fifth gear M/S—needle cage bearing K 16x21x10	913
Bearing on the second gear L/S—needle cage bearing K 20x24x12	3757
Bearing on the first gear L/S—needle cage bearing, K 16x21x10	913
CLUTCH	
Clutch bearing—needle cage bearing, K 24x28x13	796
Push pin bearing—flat cage bearing, AXK 1528	1084

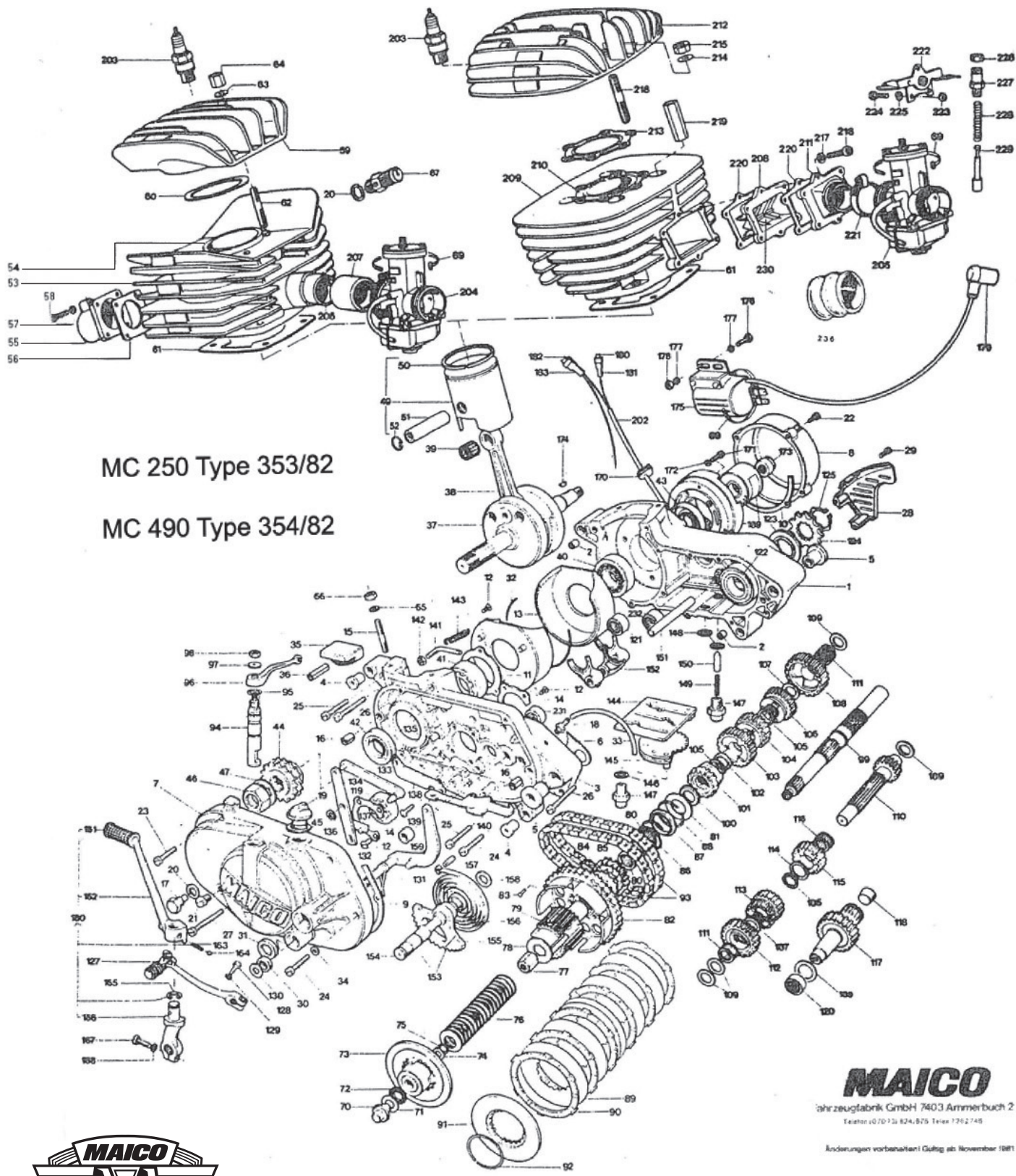

MC 250 Type 353/82

MC 490 Type 354/82



MAICO

Werkzeugfabrik GmbH 7403 Ammerbuch 2
Telefon (0 71 73) 824, 825 Telex 1262 748

Änderungen vorbehalten! Gültig ab November 1981

Blatt II

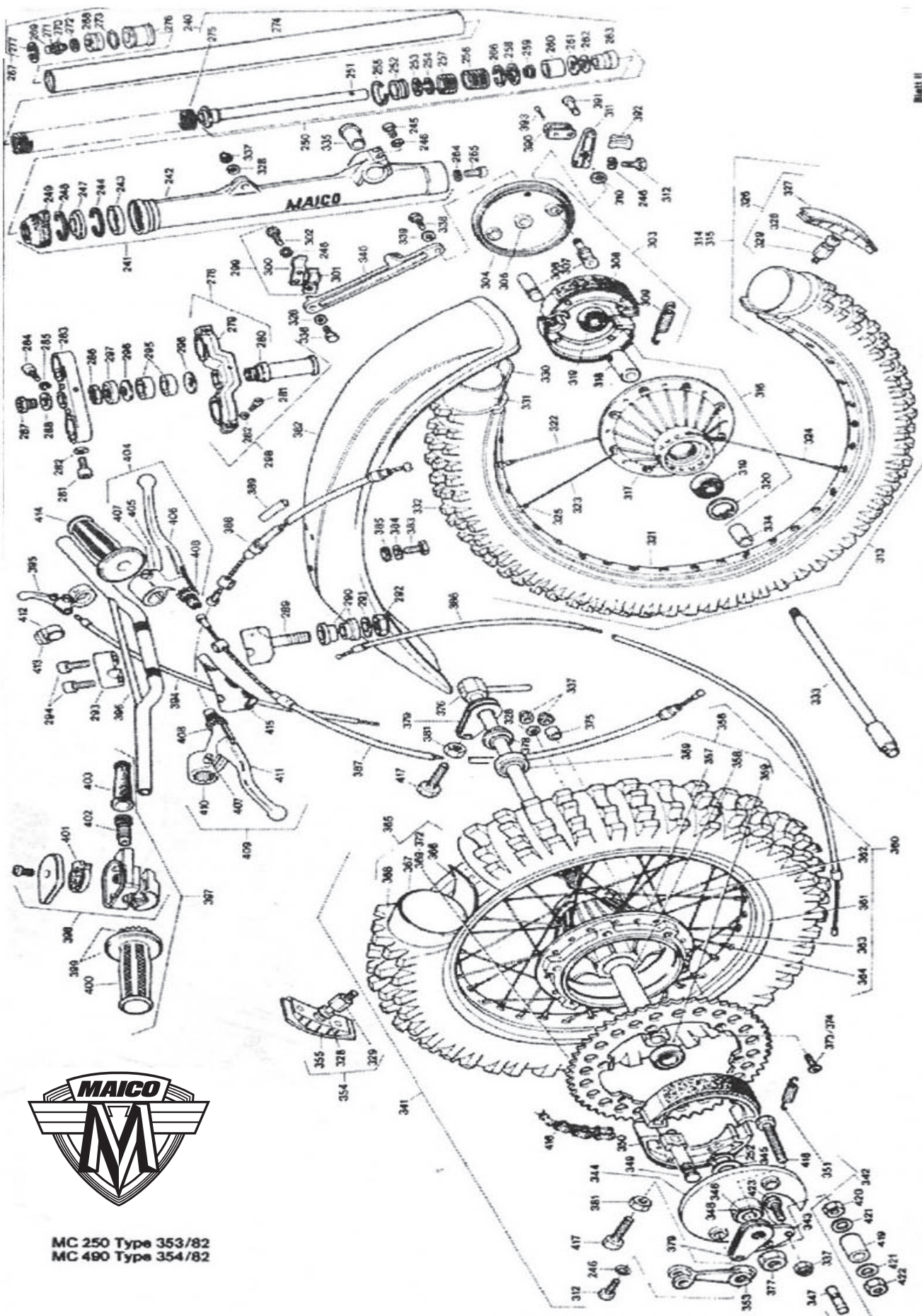

MC 250 Type 353/82
 MC 490 Type 354/82

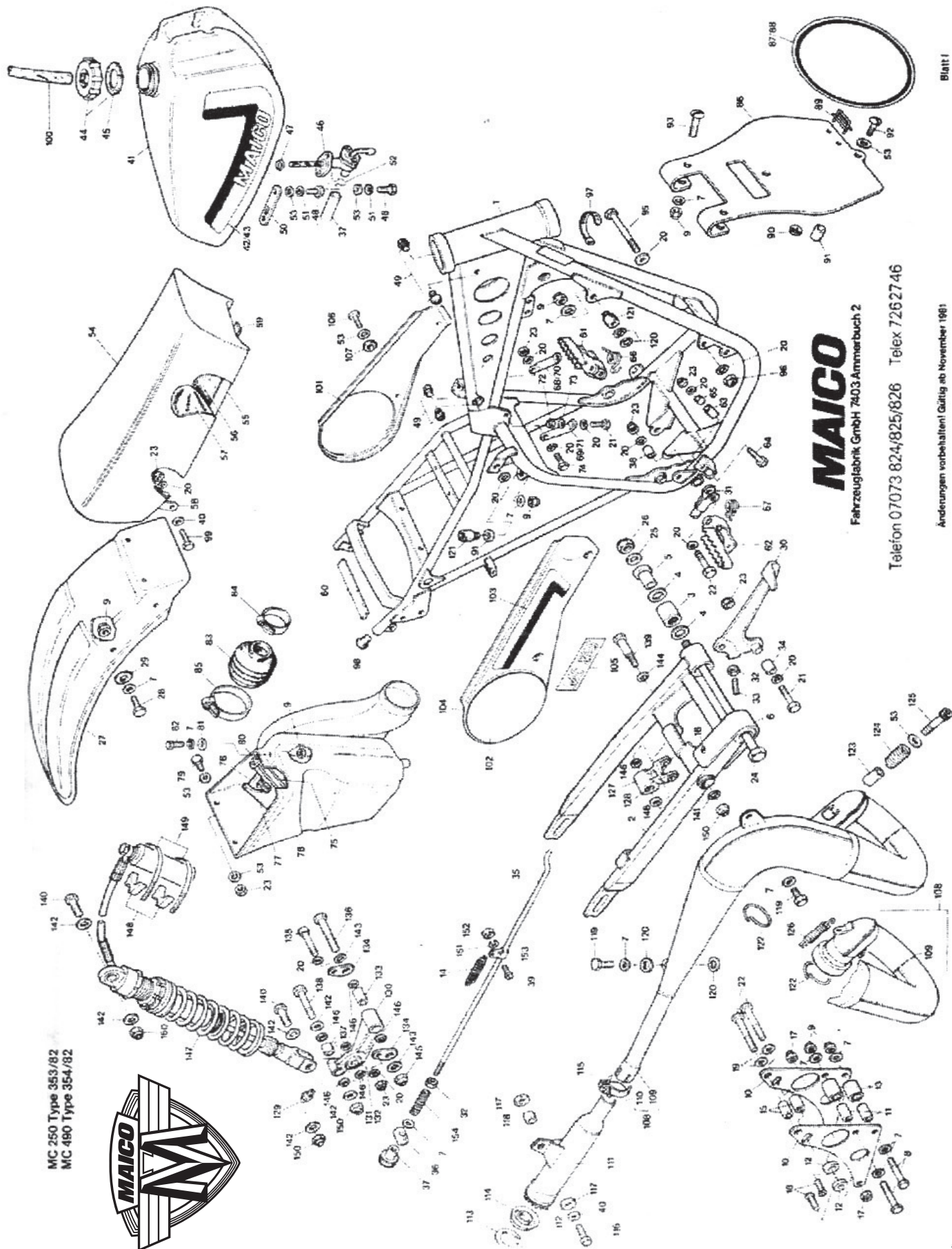

MC 250 Type 353/82
 MC 490 Type 354/82



MAICO

Fahrzeuginfabrik GmbH 7403 Ammerbuch 2

Telefon 07073 824/825/826 Telex 7262746

Änderungen vorbehalten! Gültig ab November 1981